

Don't try Sing 1964



THE NINTH ANNUAL
SANTA BARBARA
folk dance
conference

UNIVERSITY EXTENSION
UNIVERSITY OF CALIFORNIA

Ninth Annual
FOLK DANCE CONFERENCE

Sponsored by
The Department of Dance
and
University Extension
University of California, Los Angeles

in Cooperation with
The Folk Dance Federation of California, South

August 16 - 23, 1964
at
Santa Barbara, California

ABBREVIATIONS USED IN THE SYLLABUS

bkwd or bwd	backward
CCW	counter-clockwise
COH	Center of Hall
cpl	couple
ct or cts	count
ctr	center
CW	clockwise
diag	diagonal
dn	down
ft	foot
fwd	forward
H	hand
L	left
LOD	line of direction
M	man
meas	measure
opp	opposite
pos	position
ptr	partner
R	right
RLOD	reverse line of direction
sdwd or swd	sideward
twd	toward
W	woman
wt	weight

1964 SANTA BARBARA FOLK DANCE CONFERENCE

INDEX BY TEACHER

TEACHER	DANCE	NATIONALITY	PAGE
CZOMPO, Andor	Böjti Seta	Hungarian	1
	Dudari Lakodalmas	Hungarian	3
	Kalocsi Körtánc	Hungarian	5
	Kevi Csárdás	Hungarian	7
	Szatmári Verbunk És Csárdás	Hungarian	9
	Tapei Darudöbögi	Hungarian	12
	Terenyei Sergo	Hungarian	14
	Tubarozsa Csárdás	Hungarian	16
DUNIN, Elsie	Bitola Moj Roden Kraj	Yugoslavian	18
	Buvčansko	Yugoslavian	19
	Cigancica	Yugoslavian	20
	Crnagorka	Yugoslavian	21
	Potrčano	Yugoslavian	23
<i>Dani Passa</i> EVANCHUK, Vincent	<i>Debka Habir</i>	<i>Israeli</i>	<i>96</i>
	Arkan Iz Smodne	Ukranian	24
	Khorovod	Ukranian	26
	Tabakaryaska	Moldavian	29
GELMAN, Morrie	Bavarian Zweifacher	Bavarian	30
	Reit Im Winkl Schuh- plattler	Bavarian	31
GREENE, Madelynne	Halemaumau	Hawaiian	33
	Hora Din Clejani	Rumanian	35
	Kerry Reel, The	Irish	36
	Lanntti	Finnish	40
	Vira de Samonde	Portuguese	41
	Viron Polka	Estonian	43
JOUKOWSKY, Anatol	Detva Czardas	Slovakian	45
	Ergensko Oro	Macedonian	47
	Our Katia	Russian	48
NEWMAN, Oliver "Sonny"	Ballos	Greek	50
	Karapataki	Greek	55
	Kritikos Syrto	Cretian	57
	Papuri	Turkish	58
	Pentazalis	Cretian	60
	Temilav	Turkish	62
	Vari Hassapiko	Greek	64
	W Dolina	Polish	67
	Zagoritiko	Greek	70
	Zeybekiko	Greek	71

1964 SANTA BARBARA FOLK DANCE CONFERENCE

INDEX BY TEACHER (CONT'L)

TEACHER	DANCE	NATIONALITY	PAGE	
PILLICH, William F.	Let's Get The Most Out Of Ballroom Dancing!	American	73	
	General Information		74	
	Dance Positions and Leading and Following		75	
	List of Abbreviations		76	
	Tango	Latin-American	76	
	Rumba	Latin-American	77	
	Samba	Latin-American	78	
	Waltz	American	79	
	Variations on a Theme (Waltz, Tango)	American	80	
	SMITH, C. Stewart	Bonnie Anne	Scottish	81
		Cumberland Reel	Scottish	84
Glasgow Highlanders, The		Scottish	85	
Machine Without Horses, The		Scottish	87	
Waltz Country Dance		Scottish	88	
<i>The Binks of Invermay</i>		<i>Scottish</i>	<i>88H</i>	
ULLRICH, Elizabeth and GELMAN, Morrie	Der Pfeifer	Austrian	89	
	Dr Eigtaler	Swiss	91	
	Erzgebirgiseher Volkstanz	German	93	
	Stampf Polka	Swiss	95	

1964 SANTA BARBARA FOLK DANCE CONFERENCE

INDEX BY TITLE OF DANCE

DANCE	NATIONALITY	TEACHER	PAGE
Arkan Iz Smodne	Ukranian	Evanchuk	24
Ballos <i>from Kasos</i>	Greek	Newman	50
Bavarian Zweifacher	Bavarian	Gelman	30
Bitola Moj Roden Kraj	Yugoslavian	Dunin	18
Böjti Seta	Hungarian	Czompo	1
Bonnie Anne	Scottish	Smith	81
Buvčansko	Yugoslavian	Dunin	19
Cigancica	Yugoslavian	Dunin	20
Crnagorka	Yugoslavian	Dunin	21
Cumberland Reel	Scottish	Smith	84
Der Pfeifer	Austrian	Ullrich and Gelman	89
Detva Czardas	Slovakian	Joukowsky	45
Dr Eigetaler	Swiss	Ullrich and Gelman	91
Dudari Lakodalmas	Hungarian	Czompo	3
<i>Debka Habir</i>	<i>Israeli</i>	<i>Dassa</i>	<i>96</i>
Ergensko Oro	Macedonian	Joukowsky	47
Erzgebirgiseher Volk- stanz	German	Ullrich and Gelman	93
Halemaumau	Hawaiian	Greene	33
Hora Din Clejani	Rumanian	Greene	35
Glasgow Highlanders, The	Scottish	Smith	85
Kalocsi Kortanc	Hungarian	Czompo	5
Karapataki	Greek	Newman	55
Kerry Reel, The	Irish	Greene	36
Kevi Csardas	Hungarian	Czompo	7
Khorovod	Ukranian	Evanchuk	26
Kritikos Syrto	Cretian	Newman	57
Lanntti	Finnish	Greene	40
Let's Get The Most Out Of Ballroom Dancing!	American	Pillich	73-76
Machine Without Horses, The	Scottish	Smith	87
Our Katia	Russian	Joukowsky	48
Papuri	Turkish	Newman	58
Pentazalis	Cretian	Newman	60
Potrčano	Yugoslavian	Dunin	23

DANCE	NATIONALITY	TEACHER	PAGE
Reit Im Winkl Schuh- plattler	Bavarian	Gelman	31
Rumba	Latin-American	Pillich	77
Samba	Latin-American	Pillich	78
Stampf Polka	Swiss	Ullrich and Gelman	95
Szatmari Verbunk Es Csárdás	Hungarian	Czompo	9
Tabakaryaska	Moldavian	Evanchuk	29
Tango	Latin-American	Pillich	76
Tapéi Darudobogó	Hungarian	Czompo	12
Temilav	Turkish	Newman	62
Terenyei Sergó	Hungarian	Czompo	14
Tubarozsa Csárdás	Hungarian	Czompo	16
<i>The Binks of Invermay</i>	<i>Scottish</i>	<i>Smith</i>	<i>88A</i>
Variations on a Theme (Waltz, Tango)	American	Pillich	80
Vari Hassapiko	Greek	Newman	64
Vira de Samonde	Portuguese	Greene	41
Viron Polka	Estonian	Greene	43
Waltz	American	Pillich	79
Waltz Country Dance	Scottish	Smith	88
W Dolina	Polish	Newman	67
Zagoritiko	Greek	Newman	70
Zeybekiko	Greek	Newman	71

1964 SANTA BARBARA FOLK DANCE CONFERENCE

INDEX BY NATIONALITY

NATIONALITY	DANCE	TEACHER	PAGE
AMERICAN	Let's Get The Most Out Of Ballroom Dancing!	Pillich	73-76
	Variations on a Theme (Waltz, Tango)	Pillich	80
	Waltz	Pillich	79
AUSTRIAN	Der Pfeifer	Ullrich and Gelman	89
BAVARIAN	Bavarian Zweifacher	Gelman	30
	Reit Im Winkl Schuhplattler	Gelman	31
CRETIAN	Kritikos Syrto	Newman	57
	Pentazalis	Newman	60
ESTONIAN	Viron Polka	Greene	43
FINNISH	Lanntti	Greene	40
GERMAN	Erzgebirgiseher Volkstanz	Ullrich and Gelman	93
GREEK	Ballos	Newman	50
	Karapataki	Newman	55
	Vari Hassapiko	Newman	64
	Zagoritiko	Newman	70
	Zeybekiko	Newman	71
HAWAIIAN	Halemaumau	Greene	33
HUNGARIAN	Bójtí Seta	Czompo	1
	Dudari Lakodalmas	Czompo	3
	Kalocsi Kortánc	Czompo	5
	Kevi Csárdás	Czompo	7
	Szatmári Verbunk És Csárdás	Czompo	9
	Tápei Darudobogo	Czompo	12
	Terenyei Sergó	Czompo	14
	Tubarozsa Csárdás	Czompo	16
IRISH	Kerry Reel, The	Greene	36
LATIN-AMERICAN	Rumba	Pillich	77
	Samba	Pillich	78
	Tango	Pillich	76
MACEDONIAN	Ergensko Oro	Joukowsky	47
MOLDAVIAN	Tabakaryaska	Evanchuk	29
POLISH	W Dolina	Newman	67

1964 SANTA BARBARA FOLK DANCE CONFERENCE

INDEX BY NATIONALITY (CONT'D)

NATIONALITY	DANCE	TEACHER	PAGE
PORTUGUESE	Vira de Samonde	Greene	41
RUMANIAN	Hora Din Clejani	Greene	35
RUSSIAN	Our Katia	Joukowsky	48
SCOTTISH	Bonnie Anne	Smith	81
	Cumberland Reel	Smith	84
	Glasgow Highlanders, The	Smith	85
	Machine Without Horses, The	Smith	87
	Waltz Country Dance <i>The Minko at Tavenmay</i>	Smith <i>Smith</i>	88 <i>88 A</i>
SLOVAKIAN	Detva Czardas	Joukowsky	45
SWISS	Dr Eigetaler	Ullrich and Gelman	91
	Stampf Polka	Ullrich and Gelman	95
TURKISH	Papuri	Newman	58
	Temilav	Newman	62
UKRANIAN	Arkan Iz Smodne	Evanchuk	24
	Khorovod	Evanchuk	26
YUGOSLAVIAN	Bitola Moj Roden Kraj	Dunin	18
	Buvčansko	Dunin	19
	Cigancica	Dunin	20
	Crnagorka	Dunin	21
	Potrčano	Dunin	23

ERRATA FOR 1964 SANTA FOLK DANCE

CONFERENCE SYLLABUS

Page

- 4 DUDARI LAKODALMAS. At the very end of the dance description, add: "Dance ends with action of Fig. IV, meas 1-3, with this variation on meas 3: step to R with R, (ct 1); continue to R with step on L (ct 2); close R to l without rising (ct 3); hold (ct 4). There is no flourish of hands.
- 5 Change spelling of title to KALOCSAI KORTANC, pronounced Ka-lo-cha-ee
- Part I, meas 15: change cts 2 and 3 to read:
ct 2 step L ft in place
ct 3 Rock back onto heels, wt on both ft.
- 7 Under "Source", change spelling of Terkeve to Turkeve.
- NOTE: Before reproducing any of Andor Czompo's dance notes, you MUST have written permission from him.
- 12 TAPEI DARUDOBOGO. INTRODUCTION, LADY, meas 1-12, line 5: After the word parallel, add "palms fwd".
- PART I, MAN, Meas 1, line 4: After the words Leap onto R ft, add: "making a 1/4 turn to face ptr" etc.
- Line 6: Change "1/2 turn to L" to read: "1/4 turn to L, so as to face CW in circle. (ct 4)"
- LADY, meas 1, line 4: After the words, "Leap onto L ft," add: ", making a 1/4 turn to face ptr",etc.
- 13 Under PART I, (Continued) LADY, line 1: Change "1/2 turn to R" to read: "1/4 turn to R, so as to face CW in circle" (ct 4)
- 24 ARKAN IZ SMODNE: Arkan Step: Style: Ft are kept low to the floor, toe is turned down and out.
- 26 KHOROVOD. After heading "Music", add: "Record", Festival Folkshop, special recording.
- 27 Figure I, line 3: Add: "1 1/4" before the word "CCW".
- Figure 5, line 1: Change to read, "M execute PRECID DO BEEK twice through the arch" etc.
- Last line: After the word "(CCW)", add: "with DORIZKA steps."

ERRATA FOR 1964 FOLK DANCE CONFERENCE (Continued)

Page

29

TABAKARYASKA. Under the heading "MUSIC", add "Record:
Moysseyev Spectacular, ALP(S) 189, side 2, band 4.

STEP #2: Change all to read:

Meas 1 ct 1 Step fwd onto full R ft.
ct 2 Step fwd onto L, at the same time
bringing R knee up and fwd so that
knees almost come in contact
and turn R toe out to R, ready to
Meas 2 ct 1 Leap from the L ft onto the R ft
ct 2 Step slightly fwd on L.

DANCE PATTERN for Moysseyev record:

INTRODUCTION 6 meas

Figure 1: Dance step-pattern #2 six times (12 meas).

Figure 2: Dance step-pattern #1 six times (12 meas).

Figure 3: Dance step-pattern #3 three times (6 meas).

Repeat Figures 1, 2, 3 twice more (three times in all).

Then repeat Figure 1 (Step-pattern #2 danced 6 times).

Following this, there is a three meas phrase in which you
dance step-pattern #1 once PLUS a repeat of the action
of meas 2 of pattern 1. Continue the dance with Figure 2
and Figure 3, then Figure 1 and 2 again.

ERRATA FOR 1964 FOLK DANCE CONFERENCE SYLLABUS

Page

31 REIT IM WINKL SCHUHPLATTLER. After "STEPS", insert the following Style notes:

MEN: In Bavarian Plattling when the thigh is being slapped, it is raised so that it is parallel to the floor; the leaping motion in good Plattling comes when the man shifts his weight to alternately raise one knee and then the other in order to slap the thighs or shoes. The slap of either foot behind the body should be done with the body held upright; don't reach for the foot, don't drop the shoulder, don't twist the body and don't windmill the arms. Hands are held at shoulder level, elbows down, when they are not slapping a thigh or a foot.

WOMEN: While twirling (Drehing) fairly flat-footed, the head is held erect, no spotting, left hand is on left hip, right hand holding lower right corner of apron is also on left hip near left hand.

COUPLE:: When the men move clockwise around the inside of the women's circle they are in a slightly crouched position taking one step to each measure of music (1, 2, 3), while the Plattle music is continuing. As the men pass the women they can flick the skirts in playful gesture while emitting loud shouts of "Too yoo hooley." When the Plattle music ends and the waltz music (Dreher) starts the men move forward quickly stepping in time to the music (1, 2, 3, 4, 5, 6). They catch their girls around the waist with the left arm as they join them in the waltz turn; the man's left and girl's right arm held straight and pointed down at an angle toward the floor. (This is a tricky catch and requires practice, the man must move quickly to the outside of the circle as he puts his left arm around the girl's waist and stops her twirling).

35 HORA DIN CLEJANI: Figure 3, meas 17-20, take 8 liltng steps, not skips.

43-44 VIRON POLKA: Figures II through VIII are repeated before Figure IX FINALE.

45 DETVA CZARDAS. Phrase IV, line 1: Change to read: "...M turn 1/4 R to face away from ctr. W step to outside to face patr." Delete: "with back to ctr."

Figure II, meas 3: Change to read; "...moving away from ctr.."
meas 4: Change to read: "Moving twd ctr, step L (ct 1); R (ct 2); close L to R (ct 3); hold (ct 4)."

ERRATA FOR 1964 FOLK DANCE CONFERENCE

Page

- 46 After description for Figure III, insert: "Repeat action Figure II".
- Change titles of Figure IV and Figure VI to read: Circling CW.
Figure VI, lines 2-3: eliminate words "to take same pos as at end of Phrase IV."
- 47 ERGENSKO ORO. ENDING: End of dance is as follows:
- Do basic Step I and II, but in Step II,
R ft (ct 6) is placed on floor and L ft
is raised (ct 7).
- 55 KARAPATAKI. Change RECORD to "Slavjani 1002".
- 57 KRITIKOS SYRTO. FORMATION: Add "Lines should be composed of 5 or 6 people, hands held shoulder ht, elbows somewhat bent."
- 70 ZAGORITIKO. Variation for meas 3 for M only: Rise on ball of L ft, raising L knee high (ct 1): with R knee still lifted, lower L heel (ct 2); step on R beside L (ct 3); tap L heel (ct 4).
- 71 ZEYBEKIKO, STEP II, meas 1, ct 4, line 3: Change to read; "(half-turn is CCW)".
- 80 VARIATIONS ON A THEME. At the bottom of the page, just above horizontal line, add figures: The whole line should read:
- "READ Forward L 1 S 1-2"
- 92 DR EIGETALER (Cont'd). After Figure 4, the notes should read:
- Meas 1-8 Repeat Fig. 1A
Meas 1-8 Repeat Fig. 1B
- Meas 9-12 Repeat Fig. 2 meas 9-12
ETC.

ERRATA FOR 1964 FOLK DANCE CONFERENCE

Page

93

Title of dance is "DER VOGELBAERBAUM". Translation: "The Birds in the Berry Tree".

STEPS: Waltz step: Step fwd a long step (ct 1); step fwd a very short step (ct 2); step close (ct 3).

FORMATION: Add: W free hand on skirt, M free hand on hip.

Immediately under MEAS, add: Intro, 4 meas. No action.

FIGURE I. Add: (W use oppos ftwork throughout Fig. I)

- Meas 2 Begin sentence with "Rpt action of meas. 1," starting..
- 3-4 Change to read: "Make 1 complete turn (M, CCW; W, CW in LOD with: Step L (cts 1-2); step R (ct 3); step L (Meas 4).
- 5-6 Reverse action of meas 3-4, moving in RLOD.
- 7-8 Rpt action meas 3-4.
- 9-16 Delete words "under arm hold and" and Add: "Take upper arm hold for action of meas 17-32."

FIGURE II. Add: "(W use oppos ftwork throughout Fig II). Move in LOD.

- 1-4 Line 2: After the word, "hands", add "on cts 2 and 3 of each meas."
- 5-16 Line 2: Change to read "take shoulder-waist pos".

94

FIGURE III. Change word "Couples" to "Ptrs".

- 1 Change words "Fwd twd circle" to "diag L and fwd in LOD".
- 2 Change words "Out of circle" to "diag R and fwd in LOD."
- 3-4 Add: Do not take wt on last ct of meas 4.
- 5-6 Add: Do not take wt on last ct of meas 6.
- 17-18 Timing for step-close balance is: Step fwd (cts. 1-2); close (ct 3); step fwd (cts 1-2, meas 18); hop, extending free leg bwd (ct 3, meas 18).

95

STAMPF POLKA: FORMATION: Change to read: "Ptrs facing each other in a single circle, hands on own hips, M facing in LOD, W in RLOD.

Immediately under "meas", write in "Ct 4 & intro".

- 1 Change to read: Two Step-close steps swd twd ctr of circle.
- 2 Change to read: Step swd twd ctr (ct 1): stamp twice (M with R, W with L) (cts 2,3); hold (ct 4). Do not take wt on last stamp. MEAS 3-4: Add: "Ptrs are in upper arm hold. The first polka moves CW, the second moves CCW."

1964 SANTA BARBARA FOLK DANCE CONFERENCE

Presented by Andor Czompo

BÖJTI SETA (Lent Walk)
(Hungarian Folk Dance)

Pronunciation: Bö-tee Shay-ta

NO MUSIC NEEDED

Village folks, because of their Christian religion, were not permitted to dance during Lent. But, during that time the girls strolled in lines and sang. The boys usually followed them. Sometimes at the end of the street, they formed a circle to finish a song and they walked again. This was not actually a dance, but they tried to create the same feeling. It is performed without instrumental accompaniment. The melody is hummed:

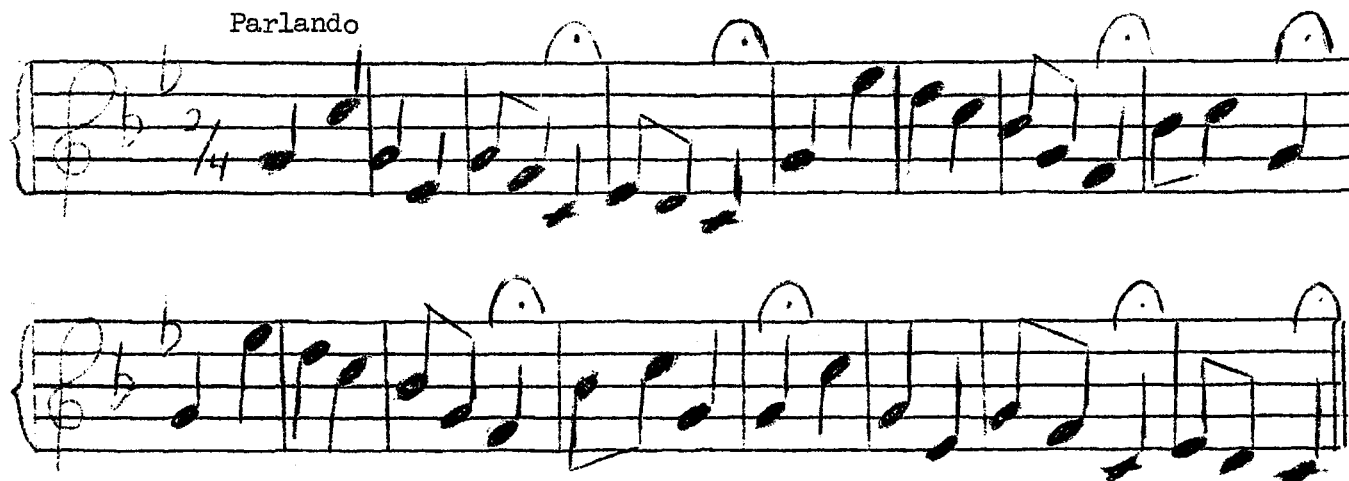

FORMATION: Girls: short lines facing Counterclockwise in a circle. "Escort" position: each girl has Left hand on own hip. Rest Right arm on inside of neighbor's elbow. Men: short lines with shoulder hold or individually, between the girls' lines.

PART I

Meas. 1	Walk forward, Right, Left.
2	Repeat Meas. 1
3	One-step Csardas to the Right: Step Right, close Left foot to Right, without weight.
4	Repeat Meas. 3 with opposite footwork.
5-16	Repeat Meas. 1-4, three more times.

PART II

1	Girls
1	Step Right on a Right/forward diagonal.
2	Step Left directly in back of Right.
2	Step Right on a Right/forward diagonal, bringing Left foot to Right ankle.
2	Step Left to the Left, bringing Right foot to Left ankle
3-16	Repeat Meas. 1-2, seven more times.

BÖJTI SETA (CONT'd) Page -2-

PART II (continued)

		<u>Men</u>
1	1	Step Right on Right/forward diagonal.
	2	Touch Left heel on the floor, without taking weight.
2	1	Step Left foot to the Left.
	2	Close the Right foot to the Left.
3-16		Repeat the 2 measure sequence seven more times.

PART III

		<u>Girls</u>
1-3		Repeat the footwork of Part I, meas. 1-3. Lines begin to move (the Left-hand lady sets as a pivot) so that all the girls form one circle.
4-16		Continue footwork of Part I in circle formation, moving Counterclockwise.

		<u>Men</u>
1-16		Men repeat the footwork of Part I, and also form a circle. This circle will be on the outside of the girls' circle.

PART IV

1-16		(Girls and Men) Repeat Part II in circle formation, moving Counterclockwise.
------	--	--

Dance directions prepared by Ann I. Czompo, Northern Illinois University, DeKalb, Illinois.

1964 SANTA BARBARA FOLK DANCE CONFERENCE

Presented by Andor Czompo

DUDARI LAKODALMAS
(Hungarian Couple Dance)Pronunciation: Doo-dar-ee Locko-doll-mahsh

RECORD: FOLK DANCER MH 2080

SOURCE: This dance was first presented at Maine Folk Dance Camp, 1963, by Andor Czompo.

FORMATION: Girl stands in front and slightly to Right of man, both facing forward around the floor, man on inside, girl on outside. Her Right hand is held up at Right, elbow bent, held by man in his own Right. Free left hands on own hips.

PART I

Meas. 1

In this position, both step forward with Right foot (ct. 1); shift weight back onto Left foot in place, keeping body erect (ct. 2); step forward with Right foot again (ct. 3).

2

Move forward with same step as Meas. 1, but starting with Left foot.

3-4

While man does 6 steps marking time in place, girl makes a circle clockwise under raised joined hands in 6 walking steps, returning to original position.

5-8

Repeat movements of Meas. 1-4.

PART II

Meas. 1-2

Same movements as Meas. 1-2 of Part I.

3-4

Using 6 walking steps and with man acting as pivot, make one full turn as a couple counterclockwise, man dancing more or less in place as he turns, and girl walking around "the outside." Keep same basic position throughout.

5-8

Repeat the movements of Meas. 1-4, excepting that on the end of the turn the girl makes an additional $\frac{1}{2}$ turn left to face man, joining both hands with him (Left in Right, Right in Left). Note that the girl must "fake" an extra small step on Right foot at very end in order to have Left foot free for the next movement. At this point partners are facing, man's left shoulder toward center, girl's right shoulder toward center.PART III

1-2

As man moves forward with identical steps to those used in Meas. 1-2 of Part I, girl backs up with the same type of step, beginning with the Left foot stepping backward.

3-4

Both partners place left hand on own hip, joining Right hands; while man does 6 steps in place, girl makes a clockwise turn under joined hands in 6 walking steps. At the end of turn, rejoin both hands.

5-6

Same as Meas. 1-2 of this part.

7-8

Same as Meas. 3-4 of this part, excepting that the girl makes $\frac{1}{2}$ turn clockwise in 6 steps, plus a small "fake" step

DUDARI LAKODALMAS (CONT'D) Page -2-

freeing Right foot for the next figure. Partners are in the original positions at this point.

Now repeat the ENTIRE SEQUENCE of Parts I-II-III one more time.

PART IV

- 1 (SLOW CSARDAS) New music.
 ct. 1 In shoulder-waist position both step right with Right foot, beginning to revolve.
 ct. 2 Continue to revolve counterclockwise with step on Left foot.
 ct. 3 Close Right foot beside Left foot and rise on toes turning so as to bring Right shoulders closer together, facing slightly Left.
 ct. 4 Settle gently down onto heels with flex of knees ("sit down.").
- 2 Same as Meas. 1, but revolving clockwise and using opposite footwork.
- 3 Same as Meas. 1.
- 4-6 10 walking steps clockwise, closing feet and rising on toes on count 11 and settling heels on count 12. Begin this whole series with Left.
- 7-9 Same as Meas. 4-6 but opposite direction and opposite footwork.

NOW REPEAT ALL OF MEAS. 1-9 EXACTLY OPPOSITE, BEGINNING WITH STEP LEFT ON LEFT FOOT, REVOLVING FIRST CLOCKWISE, ETC., FOR MEASURES 10-18. CONTINUE REPEATING THE SEQUENCE OF MEASURES 1-18 UNTIL THE END OF MUSIC. NOTE THAT THE DANCE PHRASE DOESN'T FIT THE MUSICAL PHRASE.

Dance directions by Dick Crum. Prepared for distribution by Ann I. Czompo, Northern Illinois University, DeKalb, Illinois.

Addition to notes

At the very end of the dance description add: "Dance ends with action of Fig IV, meas 1-3, with the variation on meas 3: step to R with R, (ct 1); continue to R with step out (ct 2); close R to L without rising (ct 3) hold (ct 4). There is no flourish of hands."

1964 SANTA BARBARA FOLK DANCE CONFERENCE

Presented by Andor Czompo

~~KALOCSI~~
~~KALOCSI~~ KÖRTÁNC
(Hungarian Circle Dance)

Pronunciation: ^{w cha-ee w} Ka-lo-~~chee~~ Kur-tants

RECORD: FOLK DANCER MH 2080

SOURCE: Kalocsi Körtánc is basically a girls' dance from central Hungary, Kalocsi region. Occasionally men join in the dance also. The dance was presented for the first time in 1964, by Andor Czompo.

MUSIC: 4/4 meter

FORMATION: Circle formation, hands joined and held low.

INTRODUCTION: 8 counts (2 measures)

PART I: Körtánc

<u>Meas.</u>	<u>Ct.</u>	
1-6	1	Facing into the center of the circle, step Right to the Right
	2	Close Left foot to Right taking weight.
	3	Step to the Right with the Right foot.
	4	Close the Left foot to the Right but do not take weight.
	5	Step to the Left with the Left foot.
	6	Close the Right foot to the Left but do not take weight.
7-24		Repeat the sequence (ct. 1-6) three more times for a total of four times.
7-8	1	NOTE: The dance phrases and music phrases do not correspond. Facing slightly to the Right, step to the Right with the Right foot.
	2	Step Left across in front to the Right
	3	Step Right with the Right foot.
	4	Close the Left foot to the Right but do not take weight.
	5	Step Left on a back/Left diagonal.
	6	Close the Right foot to the Left but do not take weight.
	7	Step Right in place.
	8	Step Left in place.
9-14		Repeat Meas. 7-8 three more times for a total of four times.
15	1	Step Right foot in place.
	2	Step Left foot in place, weight on both feet.
	3	Rock back onto heels, <i>weight on both feet.</i>
	4	Rock forward onto balls of feet, bending knees slightly.
16		Repeat Meas. 15.
		NOTE: Each melody is 8 measures, and Part I of the dance uses four melodies.

PART II

		<u>Urgés</u> (footwork the same for ladies and men)
1		Moving toward the center of the circle, take two steps, Right, Left, and one Cifra (Right, Left, Right)
2		Moving to Left, take two steps (Left, Right) and one Cifra (Left, Right, Left).

KALOCSI KÖRTÁNC (CONT'D) Page -2-

PART II (continued) Ürgés

- 3 Moving to Right, take two steps (Right, Left) and one Cifra (Right, Left, Right).
- 4 Moving back from the center of the circle, take two steps, (Left, Right) and one Cifra (Left, Right, Left).
- 5 Moving to the Right, take two steps (Right, Left) and one Cifra (Right, Left, Right)
- 6 Moving to the Left, take two steps (Left, Right) and one Cifra (Left, Right, Left).

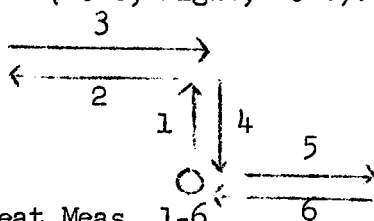

7-12
13-24

Repeat Meas. 1-6.
Repeat Meas. 1-12.

NOTE: The music is phrased in 4 measures. The dance phrase is 6 measures.

Dance directions prepared by Ann I. Czompo, Northern Illinois University, DeKalb, Illinois.

1964 SANTA BARBARA FOLK DANCE CONFERENCE

Presented by Andor Czompo

KEVI CSARDÁS
(Hungarian Couple Dance)

Pronunciation: Kev-ee Char-dahsh

RECORD: BF S-414

SOURCE: This dance is a set form of a free-style Csárdás from Törkeve, Hungary, home-town of Andor Czompo.

FORMATION: Couples in a circle. Man faces counterclockwise, woman faces clockwise in shoulder-waist position. However, man's hands are just below shoulder blades of lady, so that lady's arms are resting on man's extended arms. The entire dance is performed with slightly flexed knees. Although the dance is simple, it requires good styling.

PART I

Meas. 1-2

In place, partners facing, on each beat bend the knees, emphasizing the down movement. 4 times.

3-4

Csárdás step. Man begins the Csárdás step on Right foot moving Right: Step Right to Right, close Left foot to Right, step Right foot to the Right, close Left foot to Right but keep weight on the Right foot and bring Left foot up beside ankle. Repeat the Csárdás step on the Left beginning with the Left foot. Lady begins same Csárdás step on the Left foot moving to the Left, and repeats the Csárdás step to the Right.

5-8

Man continues the Csárdás step but instead of moving from side to side, moves forward in Line of Direction, beginning with the Right foot. This step closely resembles a ball-room two-step. Ladies do this Csárdás step backward beginning on the Left foot. The Csárdás step is done 4 times.

9-12

Continue same Csárdás step (Man, Right: Lady, Left) making a full turn (or for those who can, two full turns) counterclockwise, 4 times.

Right hips are adjacent. Finish facing your partner directly.

Part I is repeated 2 more times. At the beginning of the 2nd and 3rd repeats, replace Meas. 1 with 2 Csárdás steps (Man, Right: Lady, Left) as in Meas. 3-4.

NOTE: At the end of the third repeat of Part I, open out the couple, the lady on the right side of the man. The lady finishes the final Csárdás step Right, Left, Right, but takes one more step on the Left foot.

PART II

1-3

The same Csárdás step as described above is used throughout Part II.

Couples side by side, should hold with inside arms extended. Lady's Right hand on hip. Man's Left arm is raised, elbow bent and hand close to ear. Both begin the Csárdás step to

KEVI CSÁRDÁS (CONT'D) Page -2-

- the Right with the Right foot.
- 4-6 In the shoulder hold position, the couple makes a full turn counterclockwise as a unit. The man begins turning to his Left in place and acts as a pivot.
- 7-8 Continue the turn as in Meas. 4-6, but assume closed social dance position.
- 9 Lady makes full turn to the Right under her own Right arm and returns to social dance position in one Csárdás step.
- 10-11 Couple now continues the turn but faces the other direction (clockwise), right hips adjacent and moves forward in 2 Csárdás steps.
- 12 Lady again makes a turn under her own right arm in one Csárdás step, and returns to social dance position.
- 13-18 Repeat Meas. 7-12.

Repeat all of Part II three more times for a total of four.
NOTE: At the very end of the dance, instead of returning to social dance position, open out the couple as in Meas. 1 of Part II.

Dance directions prepared by Ann I. Czompo, Northern Illinois University, DeKalb, Illinois.

1964 SANTA BARBARA FOLK DANCE CONFERENCE

Presented by Andor Czompo

SZATMÁRI VERBUNK ÉS CSÁRDÁS
(Hungarian Couple Dance)Pronunciation: Sot-mar-ee Vair'-boonk ehsh Char'-dahsh

RECORD: Angle 65029 Verbunkos and Csardas of Szatmar

SOURCE: This dance was first presented in Boston, Massachusetts in March, 1964, by Andor Czompo.

The dance is a set form based upon the free-style Csárdás of Szatmar county, choreographed by Andor Czompo. The choreography was a "prize-winner" in one of the Hungarian National folk dance competitions in Eger, 1956.

FORMATION: Couples in a circle facing Counterclockwise. Man's Right arm around lady's waist, Left arm free. Lady's Left arm on man's Right shoulder, Right hand on hip.

PART I

Meas. 1-2

Straighten and bend knees 4 times, emphasizing the up movement.

3 3 running steps in place, Right, Left, close feet sharply together on count 3. On count 4, sharply cut onto Left foot, and project Right foot forward.

4 Moving on a Right/forward diagonal, step Right with the heel of the Right foot leading, step Left behind Right, step Right foot to side, take a small hop on the Right foot and as you hop, project Left foot to the Left/forward diagonal.

5 Repeat Meas. 4, moving to the Left/forward diagonal and reversing footwork.

6 Step Right foot to the Right/forward diagonal, step Left behind Right, step Right foot to the Right, and hold with the Left foot held off the floor.

7-12 Close Left foot to Right foot and repeat all of Meas. 1-6.

MAN'S PART

13 One slow Csárdás step to the Left: step Left foot to the Left, Close Right foot to the Left foot. Man's Right hand comes down to pocket line.

14 Take 2 Slow steps moving toward partner, Right, Left.

15 One Slow Csárdás step to the Right moving sideways toward partner. Step Right foot to the Right, close Left foot to the Right. With Left hand, take partner's Left hand and hold it down.

16 Do a Bokázó in place: Step Right, Left, Right, keeping the weight on the Right foot. Pause. Release the hand hold with partner during the Bokázó.17-18 Joining partner in social dance position, do 3 Upbeat Rida steps, starting on the Left foot. Opening out the couple to the original side-by-side position, close feet together on count 4.

SZATMARI VERBUNK ÉS CSARDÁS (CONT'D) Page -2-

LADY'S PART

- 13 With the Left foot, do a cross step in front of the Right foot, turning the hips to the Right as you step. Close Right foot to the Left, turning the whole body slightly to the Left to face partner.
- 14 With both feet together, both hands on hips, straighten and bend knees Up-down-up-down, emphasizing the up movement.
- 15 Joining Left hand with partner's Left hand, take 2 running steps, Left, Right and a Cifra step: step in place Left, Right, Left. With this combination, make a full turn to the Left, arriving on the Left side of your partner.
- 16 Continue the 2 running steps, 1 Cifra combination with opposite footwork. Make a full turn to the Right, releasing the hand hold so that you arrive slightly facing your partner and a small distance away from him.
- 17-18 Same as Man's Meas. 17-18.

BOTH MAN'S AND LADY'S PART

- 19-24 Repeat Meas. 13-18 once more.

Repeat all of PART I once more.

PART IICSARDÁS

- 1-2 Begin in the same formation as in PART I. Both partners do one slow Csardás step to the Right. Repeat to the Left. Once more to the Right and once more to the Left.
- 3 Take two small running steps, sideways to the Right: Right, Left. On count 2, shift weight to both feet, apart and parallel, standing on the balls of the feet with straight knees. On count &, bend knees. During these two counts, there is a noticeable bounce on each step. Repeat this combination, moving to the Left and beginning with the Left foot.
- 4 Repeat Meas. 3.

MAN'S PART

- 5-6 Do 2 running steps in place: Right (1), Left (&). Bring feet together, weight on the balls of both feet with knees straight (2). Bend knees on count &. Repeat this combination three more times for a total of four.

LADY'S PART

- 5 Do the same steps as the man, but move with the first two running steps from the position on the Right side of man to his Left side. Make a full turn to your Left as you move in front of the man. Repeat the step combination in place on the Left side of the man.
- 6 Repeat Meas. 5 but turn from the Left side of man to the Right side.
Make a full Right turn as you do this.

BOTH MAN'S AND LADY'S PART

- 7-8 During the first step you join in social dance position. Both do an Upbeat Rida step beginning with the Left, and

SZATMARI VERBUNK ÉS CSARDAS (CONT'D) Page -3-

moving to Left around partner. Do 6 Rida steps making 3 full turns as a couple. Open up the social dance position to the original position facing Counterclockwise Line of Direction, as you take 3 running steps: Left, Right, Left and close your Right foot to the Left.

Repeat all PART II.

Now repeat Meas. 5-8 again.

For the end of the dance, you have four more slow measures. During that time, girls can turn and walk away from man. Turn and run back to man. If the girl wishes, she can jump up into his arms, with her arms around his neck.

Dance directions prepared by Ann I. Czompo, Northern Illinois University, DeKalb, Illinois.

1964 SANTA BARBARA FOLK DANCE CONFERENCE

Presented by Andor Czompo

TAPEI DARUDÓBOGÓ
(Hungarian Couple Dance)

RECORD: FOLK DANCER MH 2079 a

This dance is very joyful, almost humorous. The footwork is sharp but light. Without proper style, this dance can be a "painful and unpleasant exercise."

INTRODUCTION

Meas. 1-12

LADY

Take walking steps toward the center of the circle beginning with the Right foot. As you step on the Right foot, turn hips slightly to the Right. At the same time arms and hands do a "waving" motion: arms are extended forward from the shoulder and are parallel. ^{palms fwd.} As you step Right, both arms move to the Right. As you step Left, both arms move to the Left, etc. With these 48 steps, Ladies move into the center, turn around, and do the steps in place until the Man joins them.

13-23

Man offers his handkerchief to Lady and leads her out of the center into a circle for the dance. The man does a step-hop (lift) moving backwards: step Right foot behind Left, lift on Right foot, bringing Left foot around to back. Repeat this combination alternating feet. Ladies do the following step pattern moving forward: step with the Right foot, close Left foot to the Right foot without weight. Step Left, close Right, etc.

24

Take this formation: Lady on Left side of Man, couple faces counterclockwise. Inside arms are joined low. Man's Right and Lady's Left arms are free.

PART IMAN

1

Take a long step forward on the Right foot, leading with the heel (ct. 1).
Then take a very small step forward on the Left foot (ct. 2).
Leap onto the Right foot and swing joined arms forward and release the hand hold (ct. 3).
Do a hop on the Right foot, making a $\frac{1}{4}$ turn to the Left. (ct. 4). *so as to face CW in circle. (ct 4).*

LADY

Take a long step forward on the Left foot, leading with the heel (ct. 1).
Then take a very small step forward on the Right foot (ct. 2).
Leap onto the Left foot, and swing joined arms forward and release the hand hold (ct. 3). *making 1/4 turn to face opp.*

TAPEI DARUDOBÖGÖ (CONT'd) Page -2-

PART I (continued) LADY

Do a hop on the Left foot, making a $\frac{1}{4}$ turn to the Right ~~(ct. 4)~~. so as to face CW in circle. (ct 4)

- 2 Join inside hands. Men begin the same step combination as described in the Lady's part of Meas. 1, but facing clockwise. Ladies do the combination as described for the Man in Meas. 1, beginning with the Right foot.
- 3-12 Repeat Meas. 1-2, alternating feet and direction.

PART IIMAN

- 1 Step forward on the Right foot, leading with the heel (ct. 1).
Take a small step forward on the Left foot (ct. 2).
Take a small jump with feet apart and parallel (ct. 3).
Click heels together in the air (ct. &).
Land on both feet apart (ct. 4) and click heels together in air again.
Land on the Left foot. The rhythmic pattern for this step is:

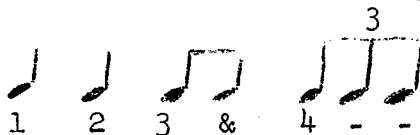
LADY

- Step forward on the Left foot, leading with the heel (ct. 1).
Take a small step forward on the Right foot (ct. 2).
Then do the same pattern as the Man with the jump, click heels together, jump, click heels together, and land on the Left foot.
- 2-11 Both Man and Lady continue the above step combination starting with the Right foot stepping forward, each time.
- 12 Both the Lady and Man step forward on the Right, Left. Close feet together and hold. Resume position described in Meas. 24 of the Introduction.

PART III

Repeat the 12 measures of PART I.

PART IV

Repeat PART II.

PART V

Repeat PART I. On the last count, close the feet together and hold.

1964 SANTA BARBARA FOLK DANCE CONFERENCE

Presented by Andor Czompo

TERENYEI SERGÓ
(Hungarian Couple Mixer)

Pronunciation: Tear-en-yeah Shar-go

RECORD: FOLK DANCER MH 2080

SOURCE: This dance was first presented by Andor Czompo at Maine Folk Dance Camp, 1963.

FORMATION: Partners in shoulder waist position, man facing toward center. Man's hands are actually a little above girl's waist.

- Meas. 1-4 In place, straighten and bend knees for 8 counts. Emphasize the up movement which comes on the beat. The movements are quick.
- 5-6 Both starting with the Right foot, move Counterclockwise with two steps Right, Left and end with a 3-count Bokázo (Bo-kaz-o) as follows:
 Ct. 1 Hop on Left foot, pointing Right foot in front.
 Ct. & Leap onto Right foot beside Left foot.
 Ct. 2 Close Left foot to Right foot.
- 7-8 Both starting with Left foot, move Clockwise with two steps Left, Right and ending in original places with a 3-count Bokázo as above, but begin with the hop on the Right foot and continue on opposite feet.
- 9 Release hold. Man steps onto Right foot, girl onto Left foot, both sway in that direction with slight turn of the upper body and clap hands.
- 10 Sway other way onto other foot, man takes girl's Right hand in his Left. Girl puts other hand on hip, man brings free hand up into air, snapping fingers if he wishes.
- 11-12 Make a dishrag turn under joined hands. During the turn take 4 steps, man beginning with Right foot, girl with the Left foot. Man turns under to the Left, girl to the Right.
- 13-14 Repeat the movements of Measures 9-10.
- 15-16 With 8 running steps, beginning with the left foot, and aided by a "pull" by the man's left hand, girl makes a 3/4 turn to the Right, releases handhold and continues on to the next man (i.e. the man standing at her partner's Right). Man in the meantime makes a Left turn in place with 8 running steps. (Actually the man may do his turn in 4 walking steps, instead of the 8 running steps. The native dancers vary this, depending upon the individual.)

On subsequent repeats of the dance, Meas. 1-4 are done as one-step-csárdás instead of the bending and straightening of the knees for 8 counts. The one-step-csárdás is as follows:

- 1 Ct. 1 Man steps to Right with Right foot as girl steps to Left with Left foot.

TERENYEI SERGO (CONT'D) Page -2-

2 Ct. 2 Man closes Left foot to Right foot as girl closes
3-4 Right foot to Left foot.
Same but with opposite footwork.
Same as Measures 1-2.

Original dance notes by Dick Crum. The revised notes were prepared by
Ann I. Czompo, Northern Illinois University, DeKalb, Illinois.

1964 SANTA BARBARA FOLK DANCE CONFERENCE

Presented by Andor Czompo

TUBAROZSA CSÁRDÁS
(Hungarian Couple Dance)

Pronunciation: Too-bo-rozha Char-dahsh

RECORD: FOLK DANCER MH 2078 Band 1

SOURCE: This dance was first presented at Folk Dance House, New York in January, 1963, by Andor Czompo.

FORMATION: Partners facing each other. Man's Left hand holding Lady's Right hand, low. Lady's Left hand on hip, Man's Right hand at pocket line.

INTRO:

Meas. 1-2

Stand in formation.

3-4

Man takes a small step with the Right foot to the Right, and keeps weight on Right foot. Bounce 3 times with flexed knee. Man's arm rises slowly. Lady does the same step with the Left foot to the Left. During this time, turn away from partner to a side-by-side position.

5-6

MAN: shift weight back to the Left foot, followed by 3 bounces on the Left foot with flexed knees. Arm comes down. Right foot remains in place.

LADY: does the same step with opposite footwork.

7-8

Repeat Meas. 3-4.

9-10

Repeat Meas. 5-6.

11-12

Repeat Meas. 3-4, but close feet together on the last count.

Man- Close Left foot to Right
Lady- Close Right foot to Left } Weight on both feet.

Finish in a side-by-side position, Lady on the Left side of Man.

PART I

Man holds Lady's Right hand in his Left hand and leads her once around him.

Meas. 1-12

MAN: Hop on the Left foot, and hit Right hand to the inside of Right foot boot top (ct. 1). Hop on Left foot, and hit Right hand on outside of Right foot boot top (ct. 2). Leap onto Right foot in place, lifting Left foot in back and hitting Right hand on inside of Left foot instep (ct. 3). This 3-count step pattern is done 8 times while the man turns once around in place Clockwise. On the last count, close feet together.

LADY:

1

Leap onto Right foot, hop on Right foot as you swing Left foot forward.

2

Leap onto Left foot, hop on Left foot as you swing Right foot forward.

3

Hop on Left foot twice as you swing Right foot in and out in front of Left foot.

4-12

Lady does this 3-Meas. combination three more times for a

TUBAROZSA CSARDAS (CONT'D) Page -2-

total of 4, encircling partner once.

PART II
1-6

MAN: Do 12 Cifra steps in place. One Cifra step: leap slightly to the Right on the Right foot. Step on Left foot in place but do not take full weight on Left foot. Step Right foot in place. To repeat, leap first onto Left foot and do opposite footwork.

7-12

LADY: Do the same type of Cifra step continuously. Take 3 running Cifra steps, making a full turn to your own Right, "turning in" to Man's arm. You will be in a wrapped up position. Do the 4th Cifra step in this position with partner to the Left. During the 5th and 6th Cifra steps, make a quick "whiplash" turn to the Left, opening out to the side-by-side position.
Repeat Meas. 1-6 once more.

PART III
1-12

MAN: In a Quick, Quick, Slow rhythmic pattern, do 3 small jumps on the balls of the feet, landing on both feet parallel. In the same rhythm, slap the thighs with the hands. Do this pattern 12 times, turning twice around Clockwise in place.

LADY: Holding skirt out to each side, encircle man (Clockwise) twice with 12 stiff-legged running Cifra steps.

PART IV
1-4

Take closed social dance position, and do 4 Upbeat Rida steps making 2 full turns Clockwise. Upbeat Rida: step on the ball of the Left foot, step on full Right foot, across in front of Left foot with knees bent.

5-6

Man does 2 Rida steps in place. Lady makes 2 full turns in place under Man's Left arm with 2 Rida steps.

7-12

Resume social dance position and repeat Meas. 1-6.

Repeat the entire dance including the Introduction once more with a slight change in PART IV.

PART IV

Same as before, but lady does one turn under Man's Left arm, because of the faster music.

FINALE:
1-12

Do 10 Upbeat Rida steps to the Left (turning Clockwise). Open out the social dance position and do 3 small running steps in place. Then close feet together.

1964 SANTA BARBARA FOLK DANCE CONFERENCE

Presented by Elsie Dunin

BITOLA MOJ RODEN KRAJ (Lesnoto)
(Macedonia, Yugoslavia)RECORD: Macedonian Songs and Dances - Orce Nikolov Ensemble, DT 1002,
side 1, band 1SOURCE: Learned by Elsie Dunin in Skopje, Yugoslavia.
A "lesnoto" type dance in 7/8 rhythm is commonly done in today's kafanas (cafe) in the cities and towns of Macedonia. The same steps with many individual variations are done to popular folk songs such as Bitola Moj Roden Kraj, Yovano Yovanke, Kako Sto e Taja Casa, and so on. When danced where there is room, the handhold is at shoulder level; however, because of limited dance space inside a kafana, dancers gather very closely with a shoulder hold.RHYTHM: 7/8 - $\begin{matrix} \underline{1} & 2 & 3 \\ \text{or slow, quick, quick.} \\ (\underline{1-2-3} & 4-5 & 6-7) \end{matrix}$

<u>Meas.</u>	<u>Ct.</u>	<u>Pattern</u>	
		<u>I. Basic</u>	
1	$\frac{1}{2}$	step R ft. to R	
	$\frac{2}{3}$	lift L ft in front of R	
2	$\frac{1}{2}$	step L ft to R crossing in front of R	
	$\frac{2}{3}$	step R ft to R, lifting L in front of R	
	3)	hold	
3	$\frac{1}{2}$	step L to L, lifting R ft. in front of L ft.	
	$\frac{2}{3}$	hold	
	3)		
		<u>II. Variation</u>	
1		repeat Meas. 1 of Fig. I.	
2	$\frac{1}{2}$	step R ft. in place	} very small steps
	$\frac{2}{3}$	step L ft. next to R ft.	
	3	step R ft. in place	
3	$\frac{1}{2}$	step L ft. to L	} very small steps
	$\frac{2}{3}$	step R ft. next to L	
	3	step L ft. in place	
		<u>III. Variation</u>	
1-2		repeat Meas. 1 and 2 of Fig. 1.	
3	$\frac{1}{2}$	step L. ft. to L	
	$\frac{2}{3}$	step R ft. behind L ft	
	3	cross L ft. to R	

1964 SANTA BARBARA FOLK DANCE CONFERENCE

Presented by Elsie Dunin

BUVCANSKO
(Macedonia, Yugoslavia)

Pronunciation: Boovf-chahn-skoh)

SOURCE: Learned by Elsie Dunin from Orce Nikolov Ensemble in Skopje, Yugoslavia, 1957. The dance was at one time performed only by unmarried girls in southwestern Macedonia near the Greek and Albanian borders.

RECORD: Macedonian Songs and Dances - Orce Nikolov Ensemble, DT 1002, side 2, band 4.

FORMATION: A line of girls or a mixed line of men and women; with straight elbows, hand hold is at shoulder level in front of body; when tempo quickens the arms come down to a low hand hold.

RHYTHM: 4/4Meas. Ct. Basic

1	1	moving diag in LOD, face diagonally L, step back with R ft.
	2	step back with L
	3	step back with R
	4	hop on R turning to face diag in LOD
2	1	step fwd with L
	2	step fwd with R
	3	step fwd with L
	4	small hop on L turning to face ctr
3	1	step R to R, holding L in place
	2	hold
	3	touch (point) L in front of R
	4	hold
4	1	step back with L
	2	step back with R
	3	step L next to R
	4	hop on R
5-8		repeat meas. 1-4

Variation

1	1	facing diag RLOD, step R fwd.
	2	step L fwd
	3	step R fwd
	4	hop on R, turning to face diag in LOD and swing L leg with straight knee in low arc.
2	1	step L fwd
	2	step R fwd
	3	step L fwd
	4	hop on L, turning to face center
3-4		repeat Meas. 3-4 of "Basic"
5-8		repeat Meas. 1-4 of "Variation"

1964 SANTA BARBARA FOLK DANCE CONFERENCE

Presented by Elsie Dunin

CIGANČICA
(Macedonia, Yugoslavia)

Pronunciation: Tsee-gahn-chee-tsah

SOURCE: Learned by Elsie Dunin from Orce Nikolov Ensemble in Skopje, Yugoslavia, 1957.

MUSIC: Macedonian Songs and Dances - Orce Nikolov Ensemble, DT 1002, side 1, band 5.

FORMATION: Mixed line of men and women; with straight elbows, hand hold is at shoulder level in front of body.

RHYTHM: 7/16; count 1,2,3; or quick, quick, slow.

Meas. Ct.

FIGURE I

1	1	facing diag. R, small leap fwd with R ft	} (small running type steps)
	2	step L ft to R ft	
	3	short step fwd with R ft	
2	1	small leap fwd with L ft	
	2	step R ft to L ft	
	3	short step fwd with L ft	
3	1	facing center, step R ft to R, lifting L knee until it is parallel with floor,	
	2)		
	3)	hop on R ft leaving L ft slightly crossed in front of R	
4	1	step L ft in place, lifting R knee until it is parallel with floor	
	2)		
	3)	hop on L, leaving R ft slightly crossed in front of L	
5		repeat Meas. 3	
6+10		repeat Meas. 1-5 with opposite footwork to RLOD.	

FIGURE II (Variation)

1-2		repeat Fig I, Meas. 1-2
3	&	small (tiny) hop on L in preparation for next ct.
	1-2	touch R toe in place
	3	lift R toe and take small leap onto R, lifting L heel in back
4	&	small (tiny) hop on R in preparation for next ct.
	1-2	touch L toe in place
	3	Lift L toe and take small leap onto L, lifting R heel in back
5		repeat Meas. 3
6+10		repeat Meas. 1-5 with opposite footwork to RLOD.

1964 SANTA BARBARA FOLK DANCE CONFERENCE

Presented by Elsie Dunin

CRNAGORKA
(Macedonia, Yugoslavia)

- SOURCE: Learned by Elsie Dunin from Orce Nikolov Folk Ensemble and Tanec Folk Ensemble in Skopje, 1957. Crnagorka is a popular holiday (sabor) dance in the Vardar Valley area.
- RECORD: Macedonian Songs and Dances - Orce Nikolov, DT 1002, side 2, band 6.
- FORMATION: Mixed line; low hand hold. Steps are performed spiritedly; M have more knee action than W (knees brought higher while doing steps). Leader signals change of Fig. by twirling a knotted handkerchief.

<u>Meas.</u>	<u>Ct.</u>	<u>Ct.</u>	<u>PATTERN</u>
			Figure I
1	1	1	Facing diag. R of ctr, moving diag in LOD, step R fwd.
	2	2	Step L fwd
2	1	3	Step R fwd
	2	4	Step L fwd
3	1	5	Step R fwd
	2	6	Turning to face center, hop on R, lifting L knee fwd
4	1	1	Facing diag. L of ctr, step L fwd
	2	2	Step R fwd
	&		Turn to face diag. R of ctr
5	1	3	Step L bwd
	2	4	Step R bwd
6	1	5	Step L
	2	6	Hop on L, slightly lifting R knee
			Figure II
1	1	1	Step R fwd)
	&	&	Step L fwd)
	2	2	Step R fwd)
2	1	3	Step L fwd)
	&	&	Step R fwd)
	2	4	Step L fwd)
3	1	5	Step R fwd
	2	6	Turning to face center, hop on R, lifting L knee fwd (as in Fig. I)
4	1	1	Turning to face L of ctr, hop on R
	&	&	Small step in place with L
	2	2	Small step in place with R
5	1	3	Turning to face center, hop on R
	&	&	Small step in place with L
	2	4	Small step in place with R
6	1	5	Step L in place lightly
	&	&	Step R in place lightly
	2	6	Step L in place lightly

2 two-steps

CRNAGORKA (CONT'd) Page -2-

<u>Meas.</u>	<u>Ct.</u>	<u>Ct.</u>	<u>PATTERN</u>
			Figure III
1	&		Small step on R toe diag. R
	1		Cross L in back of R ft
	&		Small step on R toe to R
	2		Cross L in front of R ft
2			Rpt Meas. 1
3-6			Rpt Fig. II, Meas. 3-6
<p>Fig. IV and V are for M only; W continue dancing Fig. III individually with fists at waist; M break out of line to dance in inner circle.</p>			
<p>Figure IV (CCW turns)</p>			
6	1		End of Fig. III (prep. for Fig. IV)
	2		Step L in place
			Step R (anticipate stepping fwd in Fig. IV)
1	&		Slight hop on R
	1		Step L twd center of circle, bringing hands (palms down) to waist
	&	Slight	hop on L while turning CCW
	2		Step R so as to move in LOD, but turning
2-3			Rpt Meas. 1
			(2-3 indiv. turns; pace
			Meas. 1-3) (them so as to end facing
			center.)
4-6			Rpt Fig. I, II, or III, Meas 4-6
<p>(optional)</p>			
<p>Figure V (knee twists and squats)</p>			
1	1		Arms are held high above head, palms facing fwd; facing
			LOD, in semi-squat position, pivot R ft to L, so R
			knee points diag. L, step L in place.
	2		Repeat Ct. 1 with opposite ft
2-3			Rpt Meas. 1 (Meas. 1-3) total of 6 knee
			movements
4	1		Squat to medium or low position, knees almost parallel
			but not touching.
	2		Upon rising, lift R ft (inside of ft up and knee still
			bent), hop on L
5			Rpt Meas. 4 with opposite ft.
6			Rpt Meas. 4
			(Meas. 4-6) 3 squats, alternating
			leg lifts

1964 SANTA BARBARA FOLK DANCE CONFERENCE

Presented by Elsie Dunin

POTRČANO
(Macedonia, Yugoslavia)

Pronunciation: Poh-ter-chah-no)

SOURCE: Learned by Elsie Dunin from Orce Nikolov Ensemble in Skopje, Yugoslavia, 1957.

MUSIC: Macedonian Songs and Dances - Orce Nikolov Ensemble, DT 1002, side 1, band 6.

FORMATION: Mixed line of men and women, low hand hold.

Meas. Ct. 7/16 rhythm (count 1 2 3 - slow quick quick)

1	$\frac{1}{2-3}$	facing diag. R in LOD, walk R fwd	
2	$\frac{1}{2-3}$	walk L fwd	
2	$\frac{1}{2-3}$	walk R fwd	(4 walks, but R ft takes
3	$\frac{1}{2}$	walk L fwd	a slightly longer stride
3	$\frac{1}{2}$	step R fwd	
	$\frac{3}{2}$	step L to R ft	
4	$\frac{1}{2}$	step R fwd	
	$\frac{3}{2}$	step L fwd	(2 two-steps in slow quick
	$\frac{1}{2}$	step R to L ft	quick rhythm)
	$\frac{3}{2}$	step L fwd	
5	$\frac{1}{2-3}$	turning to face center, step R to R	
	$\frac{1}{2-3}$	hop on R, L is crossed in front of R	
6	$\frac{1}{2-3}$	turning to face diag L of LOD, step L fwd	
	$\frac{1}{2-3}$	step R fwd	
7	$\frac{1}{2-3}$	turning to face diag R of LOD, step L bwd	
	$\frac{1}{2-3}$	step R bwd	
8	$\frac{1}{2-3}$	facing center, step L to L	
	$\frac{1}{2-3}$	small hop on L, kicking R fwd	
9	$\frac{1}{2-3}$	step R in place	
	$\frac{1}{2-3}$	small hop on R, kicking L fwd	
10	$\frac{1}{2-3}$	step L in place	
	$\frac{1}{2-3}$	small hop on L, kicking R fwd	

Variation on Meas. 8, 9, 10; can be done at any time during the dance, however, it is preferable for the line to watch the leader's steps.

8	&	small (tiny) hop on R in preparation for next ct.
	$\frac{1}{2-3}$	touch L toe in place
	$\frac{1}{2-3}$	lift L toe and take small leap onto L, lifting R heel in back
9	&	small (tiny) hop on L in preparation for next ct.
	$\frac{1}{2-3}$	touch R toe in place
	$\frac{1}{2-3}$	lift R toe and take small leap onto R, lifting L heel in back
10		repeat Meas. 8.

1964 SANTA BARBARA FOLK DANCE CONFERENCE

Presented by Vincent Evanchuk

ARKAN IZ SMODNE (Ukranian)

- SOURCE:** This version of the Arkan is done by the Hutzuls in the Carpathian Mountains. It comes from a village called "Smodna" and is in general classed as a semi-circle Arkan. The village is about 10 miles southeast of Kolomyja and near the Moldavian Border.
- FORMATION:** Semi-circle of men (6 or more) arms on each others shoulders.
- MUSIC:** 2/4 time, 12 measures per melody.
- RECORD:** Ethnic Folkways Library FE - 4535B-Band 2

STYLE: *Ft are kept low to the floor, toe is turned down & out*

Arkan Step:

- Meas 1, Beat 1, Step on the rt ft. to the rt.
Beat 2, Step on the left ft. to the rt., behind the rt. ft. and lift rt. to ankle height.
- Meas 2 Beat 1, Step on the rt. ft. to the rt., bring left ft. around to the front of the rt.
Beat 2, Left ft. in the air to the left side not high and not far out.
- Meas 3, Beat 1, Step on the left ft. to the right, behind the rt ft., lift the rt. ft. in front.
Beat 2, Bring the rt. ft. out to the side, ready to step on it for measure 1, Beat 1.

Prebey

- Meas 1, Beat 1,2 Same as Arkan step.
Meas 2, Beat 1 Same as Arkan step
Beat 2 Step on left ft.
Meas 3, Beat 1 Strike the rt ft. in a fwd. direction on the floor.
Beat 2 Hold

Dva Prebey

Same as Prebey, with an added strike on Measure 4, beat 1.
Hold Measure 4, beat 2.

Dva Veleki, Tre Mali

- Meas 1, 2, 3, 4 Same as Dva Prebey
Meas 5, Beat 1 Stamp the rt foot
Beat 2 Stamp the rt foot
Meas 6, Beat 1 Stamp the rt foot
Beat 2 Hold

ARKAN IZ SMODNE (CONT'D) Page -2-

Tre Minai

Meas 1, Beat 1,2 Same as Arkan Step
 Meas 2, Beat 1 Same as Arkan Step
 Beat 2 Step on left foot
 Meas 3, Beat 1 Step to face left (1/4 CCW turn) onto rt. foot across
 the front of the left ft. and to the left side of the
 left ft.
 Beat 2 Step to face rt. (1/2 turn CW) onto left foot across
 the front of the rt. foot and to the rt. side of the
 rt. ft.
 Meas 4, Beat 1 Repeat Measure 3, Beat 1
 Beat 2 Bring left ft. to the side of the rt. and swing both
 to face fwd.

Pjat Minai

Meas 1,2,3, Same as Tre Minai
 Meas 4, Beat 1 Repeat meas 3, Beat 1
 Beat 2 Repeat Meas 3, Beat 2
 Meas 5, Beat 1 Repeat Meas 3, Beat 1
 Beat 2, Bring left ft. to the side of the rt. and swing both
 to face fwd.

Pidkivka

Meas 1,2 Same as Arkan Step
 Meas 3, Beat 1 Same as Arkan Step
 Beat 2 Keep rt. ft. out to side and hit the left heel to the
 rt. heel by jumping off the left and again landing
 on the same (left) foot.

Tre Pidkivka

Meas 1,2,3 Same as Pidkivka
 Meas 4, Beat 1 Same as Meas 3, Beat 2 of Pidkivka
 Beat 2 Same as Measure 3, Beat 2 of Pidkivka

1964 SANTA BARBARA FOLK DANCE CONFERENCE

Presented by Vincent Evanchuk

KHOROVOD^s (Ukrainian)

SOURCE: Learned by Vincent Evanchuk from Cionka, in Kiev, Ukraine, 1963.

This dance, a wedding dance, is one of the oldest dance forms in the Slavic countries. It probably predates Kiev-Russ which would place it at approximately 900 A. D.

The dance is done at weddings only. Since this dance is done by the elders as well as the younger people of the gathering, it is done with great pomp, ceremony, and tranquility.

MUSIC: 2/4 time, 7 measures per phrase, 3 phrases per verse.

MUSIC:

FORMATION:

"Record" Festival Folk shop, special recording.
Couples around in a large circle facing CCW, man on the *W on m R + slightly* inside. Woman's left hand in man's left hand and both held *level of m.* out to the front. Woman's right hand down at her side, man's right arm cradling the woman's shoulders but not touching them.

STEPS: 3

1. DORIZKA (Counted 1 & 2 &)

Meas 1, Beat 1, Step down on right foot (flat)

ct Beat &, Lift weight off of right foot slightly with the weight going onto the ball of the left foot.

ct Beat 2, Down again on the right foot (flat).

ct Beat &, ~~Same as the "and" count in Beat 1.~~

Repeat on every measure.

2. NOHOO KHELAI *ct*

Meas 1, Beat 1, Step on right foot. (flat)

ct Beat 2, Swing left foot out in front with a slight lift, about 8 inches above the floor.

ct Meas 2, Beat 1, Step on left foot (flat)

ct Beat 2, Swing right foot out in front with a slight lift, about 8 inches above the floor.

Repeat every two measures.

3. PRECID DO BEEK (men only) Counted: 1 & 2 &

Meas 1, *ct* Beat 1 &, Leap to right side leading with right foot and and squat on both feet all in the one beat, also turning CCW through 90 degrees.

ct Beat 2, Hop up, to half up on right foot, left foot extended to the left side.

ct Meas 2, Beat 1, Step to the left onto ^{on} the left foot.

ct Beat &, Swing right through a 90 degree arc around in a CCW direction and step on the ball of the R foot.

ct Beat 2, Step onto the left foot.

ct Beat &, DO NOT step on right foot. Swing it through

KHOFOVOD (CONT'D) Page -2-

a 180 degree arc in preparation for the beginning of measure 1.

Repeat all the preceding except for Measure 2, Beat 2 &, which is replaced by a hold, standing on the left foot with the right foot brought to the ankle of the left.

PATTERN OF DANCE

Figure 1 (7 measures)

DORIZKA forward in line of direction around circle (CCW) for 4 measures. ²⁰⁰
Each couple executes ^{his} its own individual ^{1/4} CCW turn for 3 measures.

Figure 2 (7 measures)

Women move to center of large circle doing NOHOO KHELAI, arms at sides.
Men stand with arms down at sides.

Figure 3 (7 measures)

Men move to center, and partner, of large circle doing NOHOO KHELAI, arms at sides.
Women stand with arms down at sides.

Figure 4 (7 measures)

Couples assume original position (see formation) and doing two measures of DORIZKA, execute $\frac{1}{2}$ of a CCW turn to face out of large circle.
Couples move out of circle with 3 measures of DORIZKA.
Couples execute $\frac{1}{4}$ of a CCW turn to face into center of circle, 2 measures of DORIZKA.

Figure 5 (7 measures)

Men execute PRECID DO BEEK ^{twice} through the arch formed by his own left arm and the left arm of his partner.
During the squat the man's right shoulder and arm are pointed to the center of the large circle.
This takes 4 measures and during this time the women do 4 measures of DORIZKA in place.
For the next 3 measures the men hold without foot movement, standing on their left foot. The women do a slow, full turn, under their left arm (CCW) *with Dorizka steps*.

Figure 6 (7 measures)

All do DORIZKA for the full time, 7 measures, in the following pattern:
Measures 1 and 2: The women turn $\frac{1}{4}$ turn CCW to face out of circle and into man's right arm.
Measures 3 and 4: Both make $\frac{3}{4}$ turn CW maintaining the same relative position between partners, and end with women facing in CCW direction around large circle.

KHOROVID (CONT'D) Page -3-

- Measure 5: Man drops arm, executes $\frac{1}{2}$ turn CW and raises arm.
- Measures 6 and 7: Women move across to the right side of the man WITHOUT turning and under their own left arm.
The final position aimed at is the same as the start of the dance.

~~Figure 7 through Figure 11~~

Repeat Figure 1 through Figure 5

~~Figure 12~~

Ending

A slow measured walk off of the floor to the sides. There is no floor pattern in the direction of movement but the walk is on the beat, two steps per measure. The women places her head on the man's right shoulder and the man's right arm cradles her right shoulder.

1964 SANTA BARBARA FOLK DANCE CONFERENCE

Presented by Vincent Evanchuk

TABAKARYASKA
(Moldavian)

SOURCE: A Moldavian dance done in many circles with particular family or group variations interspersed in the basic dance.

MUSIC: GOST 5289-56, 17652 (U. S. S. R.)

RECORD: *Moysejer Spectacular, ALP(S) 189, side 2, hand 4*

FORMATION: Eight or more men and women in a circle, hands on each other's shoulders, facing obliquely CCW around circle. Women's steps are smaller and much more delicate than the men's.

STEP #1: This step is done 4 times. (8 meas.)

Meas. 1 ct 1 Step fwd. on right ft.
ct 2 Step fwd. on left foot.
Meas. 2 ct 1 Small leap-step to the rt. onto the rt. ft.
ct & Bring left ft. in front of the rt. ft. with a slight stamp (no wt) at an angle. (Toe of left is pointed out to left, heel of left is to the rt. of the rt. toe.)
ct 2 A small leap-step to the left with the left ft.
ct & Bring rt. ft. in front of the left ft. with a slight stamp (no wt) at an angle.

STEP #2: This step is done 4 times (8 meas.)

Meas. 1 ct 1 ~~Do a step to the front onto the full rt. ft.~~
ct 2 ~~Place the left foot with wt across and in front of the rt. ft. at an angle.~~
Meas. 2 ct 1 ~~Do a leap from the left ft. at the same time bending the rt. leg at the knee, and bringing it to the front in that same position so that the knees almost come in contact.~~
ct & ~~Land to the rt. onto rt. foot.~~
ct 2 ~~Rest.~~
ct & ~~Bring the left ft. to the rt. into 6th position and change weight.~~ *(6th position)*

STEP #3: This step is done 4 times (16 meas.)

Meas. 1 ct 1 Bring the rt. ft. in back of the left and step on it. With a light squat on both feet, head to the rt.
ct 2 Lifting up take a step to the left on the left ft.
Meas. 2 ct 1 Bring the rt. ft. in front of the left, and step on it. A light squat on both feet, head to the center.
ct 2 Lifting up take a step to the left on the left ft.
Meas. 3 ct 1 Bring rt. to left in 6th position.
ct 2 With a spring, place the heels in 2nd position.
Meas. 4 ct 1 With a light slap bring the soles of the feet down, and do a slight squat.
ct 2 Bring feet together in 6th position.

ok not sure for connections

TABAKARYASKA. Under the heading "MUSIC" add "Record:
Moyseyev Spectacular, ALP (S) 189, side 2, band 4.

STEP #22 Change all th read:

Meas 1 ct 1 Step fwd onto full R ft.
ct 2 Step fwd onto L, at the same time
bringing R knee up and fwd so that
knees almost come in contract
and turn R toe out to R, ready to
Meas 2 ct 1 Leap from the L ft onto the R ft
ct12 Step slightly fwd on L.

DANCE PATTERN for Moyseyev record;

INTRODUCTION 6 meas

Figure 1: Dance step-pattern # 2 six times (12 meas).
Figure 2: Dance step-pattern # 1 six times (12 meas).
Figure 3: Dance step-pattern # 3 three times (6 times).

Repeat Figures 1,2,3 twice more (three times in all).
Then repeat Figure 1 (Step-pattern #2 danced 6 times).
Following this, ~~there~~ is a three meas phrase in which you
dance step-pattern # 1 once PLUS a repeat of the action
of meas 2 of pattern 1. Continue the dance with Figure 2
and Figure 3, then Figure 1 and 2 again.

1964 SANTA BARBARA FOLK DANCE CONFERENCE

Presented by Morrie Gelman

BAVARIAN ZWEIFACHER

The Zweifacher (Two Things) is a popular and unique form of folkdance found in Bavaria. The music or song changes from 3/4 to 2/4 tempo (or vice versa) in various combinations and the dancers adjust steps accordingly between waltz (Dreher) and pivot (Dreher) steps.

Dreher means "turning" in German and the style of the 3/4 and 2/4 Dreher used in the Zweifacher should be smooth turning, level shoulders, and uniform stepping; no dip, no bounce and no knee bends.

The sequence for several Zweifachers are given below in WD symbols. "W" in the directions denotes one waltz step (L R L); "D" means one pivot step (R). For example WWDD (as in the popular Alte Kath) means 2 waltz steps (L R L, R L R) plus 2 pivot steps (L, R) to 4 meas. of the mixed music.

Here are 3 Zweifachers of increasing order of difficulty:

EISENKEILNEST
(Bavarian)

RECORD: Kögler EP 56906 45 RPM
DD WW DD WW DW DW DD WW

DIE NEUN HAUSER
(Bavarian)

RECORD: Kögler EP 56908 45 RPM
WW DDD WW DDD WW DDD WWW

SCHNEIDER
(Bavarian)

RECORD: Kögler EP 56906 45 RPM
DD W DD WW
DD W DD WW
DD W DDD WW
DD W DDD WW

1964 SANTA BARBARA FOLK DANCE CONFERENCE

Presented by Morrie Gelman

REIT IM WINKL SCHUHPLATTLER
(Bavarian)

- SOURCE:** Reit Im Winkl is a village in the Bavarian Alps about 2 hours from Munich on the road to Salzburg, Austria. This Plattle is done this way traditionally by the Munich Area Trachtenvereins (costume clubs, essentially Schuhplatter groups). The music is very old and used throughout the Alpine Region in both Germany and Austria. As is the custom many Plattles are named after villages, mountains, areas, streams, etc. in the Alps. Reit Im Winkl, as its name implies is "right in the corner" of a section of the Alps that borders on the Tirol. It is a popular ski resort in the winter time and much loved by the German people for mountain walking in the summer time. The record was made in N. Y. by Karl Weiss and his Bavarian Band. Slow the record down for the best results, remember Bavarian Plattling is slow, controlled and deliberate.
- RECORD:** Folk Dancer MH 1124 (Slow it down)
- STEPS:** Waltz: This is done flat footed with 6 equal steps so that it comes out a slow turning waltz, which is why it is called a "Dreher" by the Bavarians.
- NOTE:** Unfortunately this recording does not have the traditional entrance (eingang) music (A, B, Waltz) in the manner that Bavarians dance. It starts out with a march and goes right into the first Plattle. While the men are Plattling the girls are twirling clockwise as they move counter-clockwise around the outside of the men's circle.
- SEQUENCE:** 1st Plattle
A, A, A, A
A, B, Waltz with girl
-
- 2nd Plattle & Exit (Ausgang)
A, A, A, A
A, B, Waltz with girl
- ABBREVIATIONS:** H - Hand
F - Foot
T - Thigh

(continued)

Style notes on next pg.

REIT IM WINKL SCHUHPLATTLER (CONT'D) Page -2-

A			B		
	1.	RF Stamp		1.	RF Stamp
Slow	2. LH	LT	Slow	2. LH	LT
Count	3. RH	RT	Count	3. RH	RT
	4. RH	LF behind		4. RH	LF behind
	5. Hold			5. Hold	
	and LH	LT		and LH	RT
	6. RH	RT		6. RH	RT
<hr/>			<hr/>		
	1. RH	LF behind	Hoch	1. RH	LF behind
	2. LH	LT	or	2. LH	LT
	3. RH	RT	Auf	3. RH	R foot (spring or scissors kick)
	4. LH	LT	Sprung		
	5. RH	LF front	Slow	4. R	Knee down on floor
Fast	6. LH	LT	Count	5. R	" " " "
Count	1. RH	RT		6. R	" " " "
	2. LH	LT (or RT)	<hr/>		
	3. RH	RT		1. Rise	
	4. LH	LT (or RT)		2. Hold	
	5. RH	RF behind		3. Hold	
	6. Hold		Slow	4. Stamp, both feet	
			Count	5. Hold	
				6. LH	RT
				and RH	RT
				1. RH	LF behind
				2. LH	LT
				3. RH	R foot (scissors kick)
				4. R	Knee on floor
				5. Rise	(Turn right to outside of circle.
				6. Rise	Move clockwise toward partner.)

1964 SANTA BARBARA FOLK DANCE CONFERENCE

Presented by Madelynne Greene

HALEMAUMAU
A sitting hula - Hawaii

SOURCE: Learned from Olga and Lincoln Kanai in 1962.

MUSIC: 49th State Record No. 4574A

DESCRIPTION: Two dancers kneeling facing each other. Each holds a bamboo puili stick in R hand. L hand on waist. Before the dance begins they cross the sticks and sway to the music 20 times.
(s) single, (d) double - (tap puili stick on back of fingers)

I. "SEE" - (Tapping the back of fingertips with puili stick)
two waves with L near L eye, tap twice (s)

Measure

1 Interlude

- (1) Tap puili stick to L finger tips (palm up) chest level
- (2) Tap partner's stick
- (3) Tap back of own L finger tips (palm down)
- (4) Tap R shoulder with stick
(Body slightly rotates in a CW movement with the tapping of the stick)

"House" 1, reach high (center) one wave, tap single (raise up on knees)

"Fire" 2,3,4 Wave L hand waist level at L side 3 taps

1-2-3-4 Two Interludes (as written above but two times)

1-2 "High land" - L shoulder (s) reach out to R (d)

3-4 "Low land" - L waist level (s) reach out to R (d)

Two Interludes

Repeat I including interludes

II.

"Crown" Circle over head (from L, back, R, fwd.)

(Chiefess) Tap (s)

Repeat circle and tap

Two Interludes

"Low lands"-tap at L (s) at waist level
reach out to R (tap (d))

Repeat "low lands"

"Flat Rocks"-Sweep hands up high to L (raising up to knees)
and bring hands down slowly. (Rhythm (s) (d) (s)
(s) (return to sitting position)
Sweep hands up high to R and bring hands down
slowly (s) (d) (s) (s)

Two Interludes

Repeat II including interludes

III.

- "Speak" Mouth level (s) reach (not far) out (s)
 "See" - Eye level (s) reach (not far) out (s)
 "4 Passes" - Pass your own R stick firmly fwd into partner's L hand, at same time clasp partner's stick with your L hand. This pass is repeated 4 times in all.
 "Rain" - Reach up high tapping 4 slow taps as the hands are lowered, fingers of L hand rippling to indicate raindrops (this takes 4 slow taps and at end quickly tap stick to R shoulder.
 "Mist" - Reach high and tap (s) (raise up on knees)
 Reach low (waist level) two taps (s) (s)
 Repeat Mist
 Two Interludes
 Repeat III. (including two interludes)

IV.

- "Haina" (end of my story)
 "Speak" - Mouth (d) out to R (d)
 Mouth (d) out to L (d)
 "Lava Pits" - Clasp tip of sticks in L hand and base in R. Indicate a counter-clockwise circle and tap base on ground to your R side
 Repeat circle to your L side
 "See" - Two taps eye level
 One Interlude
 "House" - Same as in Fig. I
 "Fire" - Same as in Fig. I
 Two Interludes
 Repeat, but at end of figure do only interlude and then draw the pulli stick in a lateral position twds you, supporting the tip of the stick in the fingers of the L hand, palm up. This is the final phase of the dance.

NOTE: These notes are written expressly for the people who have studied this dance with Olga and Lincoln Kanai, or Madelynnne Greene.

Halemaumau is a fiery volcano that erupts periodically on the island of Hawaii. It is a pit situated in the middle of an 8 mile crater, Kilauea on the slopes of Mt. Mauna Loa. The pit Halemaumau is a mile in circumference and about 200 feet deep. The chain of 6000 islands spreading over a thousand miles is made by a series of volcanic actions during the past 60 million years. The last volcanic action survives to this day with the Fire Goddess continuing actively to build land masses in the middle of the Pacific Ocean.

1964 SANTA BARBARA FOLK DANCE CONFERENCE

Presented by Madelynne Greene

HORA DIN CLEJANI
(Rumania)

The easiest and most popular of Rumanian folk dances, with smooth, swaying movements.

FORMATION: Circle dance for any number of dancers from four only to several hundred. The hands are joined and held shoulder high.

MUSIC: Record: Parliament 119

Meas. FIG. I.
 1 Lilt fwd on R ft with L leg raised behind with the knee slightly bent. Lilt backward on L ft with R leg raised in front with the knee slightly bent.
 2 Three steps fwd - R (ct. 1), L (&), R (ct. 2) - closing the circle.
 3-4 Repeat the movements of meas. 1 and 2 but lilt bkwd on to L ft first, and open the circle on the 3 walks.
 5-8 Repeat the movements of meas. 1-4.

FIG. II. The Balance
 9 Step sideways on R ft and lilt, swinging the L leg across with the knee slightly bent. Repeat this, stepping on to L ft.
 10 Moving to the R, step R ft (ct. 1), cross L ft behind R (&), step sideways again with R ft (ct 2).
 11-12 Repeat the movements of meas 9-10, moving to the L and stepping on to L ft.
 13-16 Repeat the movements of meas 9-12.

FIG. III. *steps*
 17-20 8 liltng ~~steps~~ moving CCW, starting with R ft. The first two are taken with the back to the line of dance (i.e.) moving CCW with body and feet turned to face CW. The next two steps are taken facing the line of dance.
 21-24 Repeat the movements of meas 17-20 in the same way but move CW.

The dance can be repeated as often as the dancers wish.

1964 SANTA BARBARA FOLK DANCE CONFERENCE

Presented by Madelynne Greene

THE KERRY REEL

(Ireland)

An Irish Reel for Three People (1 man and 2 women)

- SOURCE: The dance was taught to Madelynne Greene by Maureen Hall, noted authority on Irish dancing in Cork, Ireland. Mrs. Hall is now residing in California.
- RECORD: My Ireland - Capitol T 10028, Side 2, Band 3 - Snow on the Mountains, or any Irish Reel. Lift needle at end of dance as there is more music than needed, or repeat dance until music ends.
- FORMATION: Trios face audience, man stands between the two women. Their hands are joined above shoulder height, women's free hands are held at sides. Woman at R is #1, Woman at L is #2.
- MUSIC: 2/4
- STEPS: Throughout the dance the basic steps will be "Sevens" and "Threes". Sometimes only "Sevens" will be danced to a phrase, sometimes only "Threes" and sometimes a combination of "Sevens" and "Threes".

"Sevens" to the Left:

Begin weight on L. Swing R ft around behind L (ct "and") step on R behind L placing weight on R (ct. 1), on ct "and" step on L ft (ct. 2) (R in back) L to side, continue counting 7 changes of weight in all R,L,R,L,R,L,R, rest.

"Sevens" to the Right:

Swing L ft around behind R accenting and stepping on L for ct 1 then step to R, ct. 2, L in back for ct 3 etc., so it will be L,R,L,R,L,R,L rest.

"Threes" are danced like a small pas-de-bas step with a tiny leap on the first count. Thus: Leap onto R (toes turned out) (ct 1) cross L and step on L (ct 2) again on R (ct 3) repeat to L.

When traveling fwd on "Threes" keep fwd on R, bring L in front for ct 2 and draw R up to L for ct 3 (toes always turned outward.)

Knees are always relaxed on accenting counts so the dancer "sinks" into the accenting step.

Arms: At any time when not holding hands with another dancer the arms for both men and women are held quietly at the sides, inside edge of the wrist close to the body, the palm facing back. Arms should always be relaxed but controlled and should not separate from the body. When hands are held they should be lifted high so arms form almost a straight

THE KERRY REEL (CONT'D) Page -2-

line from shoulder to elbow. Elbow almost touches partner's elbow. A tall, straight, good posture is important at all times. Dancers keep dancing threes in place whenever waiting in place for next step. Do not stand still while waiting.

DIAGRAMS:

^ - man facing audience (- lady facing audience
 < - man facing left (- lady facing left
 > - man facing right) - lady facing right
 v - man with back to audience) - lady with back to audience

INTRODUCTION: Wait 8 measures with R toe pointed on floor in front of dancer.

I. <u>LEAD OUT</u>	<u>Diagrams</u> <u>Audience</u>
Meas. 1-4 All dance fwd (downstage) towards audience 4 "Threes" R,L,R,L.	2 ^ 1
5-6 Ladies make complete turn (inward) under joined hands with man, dancing 2 "Threes" on the spot as man dances in place.	
7-8 Ladies change places with 2 "Threes", R Lady under arch, man following R lady under his own R arm and making 1/2 turn. All end backs to audience.	
9-16 Repeat meas. 1-8 dancing (upstage) with backs to audience returning to original places. This time lady #2 going under arch as man follows her.	1 v 2
II. <u>SEVENS IN A "FILE"</u>	
Meas. 1-4 Drop hands to sides - all dance "Sevens" to the L.	2 ^ 1
5-8 Dance "Sevens" to the R to original places.	
9-12 All make 1/4 turn to R and dance "Sevens" to audience.	↑ ↑ ↑
13-16 Dance "Sevens" to R (returning to original places).	
1-8 Make a 1/4 turn to R (back will be to audience) and dance "Sevens" to L and "Sevens" to R (back home)	2) > 1)
9-16 Make a 1/4 turn to R and dance "Sevens" to L and "Sevens" to R (moving away from audience and then home to place.) All face forward at end.	2 v 1 (2 < (1
III. <u>CHAIN</u>	
1-8 All dance "Threes" for this figure. Man dances clockwise with lady #1 holding her R hand, then goes to	

THE KERRY REEL (CONT'D) Page -3-

lady #2 and dances CCW with her holding L hand, then back to lady #1 ending in a triangle pattern on the floor, still holding her by the R hand. Lady #2 will turn slightly to R to prepare for next figure. (Man forms the point of the triangle a little in advance of the two ladies).

IV. ARCHES IN A TRIANGLE

Meas. 1-8 All dance "Threes" for this figure
 Lady #2 dances 2 "Threes" to go under arch, turns 1/2 turn R in place, 2 "Threes" then dances 2 "Threes" on the spot facing audience. Meanwhile the man holding lady #1's R hand (they stand R shoulders adjacent) dance 2 "Threes" on the spot (lady #2 goes through arch) then they draw elbows close together and dance 2 "Threes" to change places (lady #1 is dancing on the spot). Then again draw elbows close together and return to own place.
 9-16 Repeat IV. 1-8 but man now forms R hand arch with lady #2.
 Hold lady #2's R hand at end of figure.

V. STAR

Meas. 1-4 Lady #1 now adds her R hand to the joined hands of man and lady #2 to form a 3-hand star. All dance 4 "Threes" around CW returning to original triangle places.
 5-8 Man drops his hand and dances 4 "Threes" on the spot facing them while ladies continue dancing a two-hand circle, 4 "Threes" ending in original places.
 9-16 Repeat V. reversing star - holding L hands and travelling CCW.
 At end of figure ladies turn to face R with L shoulders to audience and man makes a 1/4 turn right to end with R shoulder to audience.

VI. MAN SPLITS THE LINE

Meas. 1-4 * All dance "Sevens" to the L and 2 "Threes" on the spot turning to face center of triangle; join hands to form a ring and travel CCW "Sevens" (to the R) and "Threes" in place. (The ladies end on opp. sides, man at point of triangle).
 9-16 Repeat exactly and at end of ring the ladies will be in original places facing audience and man will end with his back to audience.

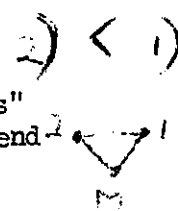

*(Be careful not to travel far as hands are to be joined to form circle.

THE KERRY REEL (CONT'D) Page -4-

VII. FORWARD AND BACK AND MAN FIGURE EIGHT

- All dance 16 "Threes".
- 1-4 Ladies travel fwd 2 "Threes" to audience (turn 1/2 to R) on spot (2).
- 5-8 Ladies travel fwd away from audience 2 "Threes" then 1/2 turn R on spot (2).
Ladies dance 8 in place facing audience.
Man at the same time dances 2 "Threes" away from audience (turns 1/2 to R on spot) 2 "Threes".
Then 2 "Threes" twds audience (turns to R 1/2 turn) 2 "Threes".
- 9-16 As ladies dance in place man goes fwd around lady $\frac{1}{2}$ passing her by L shoulder and then dances over to go around lady $\frac{1}{1}$ passing her by R shoulder and ends in center between ladies.

- VIII. All dance the lead out again (Fig. I.)

196. SANTA BARBARA FOLK DANCE CONFERENCE

Presented by Madelyne Greene

LANNITI
(Finland)

- SOURCE: This mixer was learned by June Schaal in Helsinki from Oili Alhsted, a physical education instructor. It is a traditional dance still danced in the central area of Finland.
- MUSIC: Record: Express #236
- FORMATION: Cpls in a double circle facing LOD W to MR, inside hands joined shoulder height, outside fists on hips.
- STEPS: Polka, Walk.
Steps are described for M; W dances counterpart.
- MUSIC: 2/4
- Measures
2 Introduction
- A I. FACE TO FACE AND BACK TO BACK
- 1-8 Starting with hop on R, dance 8 polka steps LOD, face to face on the first polka then turning back to back, etc., throughout.
- A rpt
- II. TURNING POLKA
- 1-8 In closed pos dance 8 polka steps turning CW and progressing LOD.
- B III. PROGRESSION
- 1 With fists on hips face ptr, M back to ctr. Keeping ft. and knees together and back straight, bend knees sharply (ct 1), straighten (ct 2).
- 2 Clap own hands 3 times (cts 1, &, 2)
- 3-4 Repeat action of meas 1-2, Fig. III.
- 5 Clap ptr R (ct 1), clap own hands (ct 2).
- 6 Clap ptr L (ct 1), clap own hands (ct 2).
- 7 With fists on hips turn away from ptr (M CCW, W CW) taking 2 steps LR (cts 1,2).
- 8 Finish facing ptr and stamp 3 times LRL (cts 1, &, 2)
- B rpt
1-8 Repeat action of meas 1-6, Fig III. On meas 7-8 during the turn away from ptr, M progress RLOD to W behind.
- Repeat dance from beginning.

1964 SANTA BARBARA FOLK DANCE CONFERENCE

Presented by Madelynn Greene

VIRA de SAMONDE (Veer'ah dey Samun'deh)
 (Santa Marta de Portuzelo, Viano do Castello, Portugal)
 A dance for two couples

SOURCE: This dance was taught to Madelynn Greene, in Santa Marta, north Portugal in 1962. It is performed by the Grupo Folclorico de Santa Marta de Portuzelo. It was by arrangement with Dr. Souza-Gomez, director and founder of the group that Miss Greene has permission to teach the dance in America.

RECORD: Radertz - EPR 601 - Star Express 227

FORMATION: Couple No. 1 stands facing couple No. 2

	Audience	
	Man	Woman
Man #1 has L shoulder to audience		
His partner stands at his R side	#1 X	O #2
Man #2 has R shoulder to audience		
His partner stands at his R side	#1 O	X #2
All hold arms curved upwards hands above head level.	Woman	Man
Fingers snap in time to music.		

MUSIC: 6/8 (Fast Waltz)

Steps: I. STEP-CLOSE-STEP PIVOT
 (Description for couple #1. Couple #2 mirrors the steps of Couple #1)
 Facing twds audience step fwd on L (ct 1-2) step R slightly in front of L (ct 3) step L fwd (ct 4), pivoting on L ft. (ct 5-6), make a 1/2 turn clockwise while raising R ft up close to L knee.

Repeat step (back to audience) on R ft. traveling away from audience. Step R, close L a little past R ft, step R and pivot to L 1/2 turn. Continue 8 times in all.

Arms: As you move fwd on L drop R arm down, back and then fwd and up (a small circle). When reversing step on R the L arm will drop down back and then fwd and up to original place. (This gives an effect of a backward stroke in swimming.) It should be a continuous movement, one circle flowing into the other, couples keep looking across the set at each other during this step. At the end of the 8th step all clap hands two times on counts 3-4 of meas. 8.

II. LONG STEP HOPS IN A FIGURE EIGHT

(Description for couple #1)

Man #1 takes long steps (covering space) a L step (ct 1-2) hop L (ct 3) R (ct 4-5) hop R (ct 6) going around partner CCW and continuing crosses to opposite lady and dances with her CW 16 step hops in all.

Woman #1 dances tiny waltz steps, 2 to a measure, accenting

VIRA de SAMONDE (CONT') Page -2-

slightly cts. 1 and 4. She faces her own partner first turning on the spot with him in a CCW direction then reverses direction as other man dances twds her and dances a CW circle. As she goes from one circle to the other it gives the effect of a figure "8" on the floor. For all the arms are held a little wider on this step than in Step I to dance close to each other. If man is taller his arms will be above hers.

Fig. 1A. The Dance

Meas. 1-8	(Described for couple #1. Couple #2 mirrors actions of couple #1) beginning on R ft. Pick up ct 6 (rest on ct. 6 - 1,2,3) Begin on ct. <u>4</u> couple #1 steps on L ft. facing to L and
1	sharply pivots 1/2 turn to R (facing away from audience) on cts 5-6
2	Traveling to R (and away from audience) do R close R; pivot
3	" " L fwd twds audience
4	" " R (meas. 2)
5	" " L
6	" " R
7	" " L
8	Step on R ct 1-2, on ct 3-4 clap hands twice accenting feet L R rest.

Fig. IIB.

1-8	Partners face each other - both begin on L ft. Man dances 16 long step-hops as lady waltzes 16 steps. He moves in a CCW direction then leaves his own partner to cross the set to opp. lady passing R shoulders and back-to-back with man #2. He then dances CW facing lady #2, leaves her and passes L shoulders with Man #2, repeats turn with own partner and again crosses in the same manner over and back home to original position.
-----	--

Dance is repeated until end of music. On the repeat begin first step as described in Fig. 1, measure 3.

1964 SANTA BARBARA FOLK DANCE CONFERENCE

Presented by Madelynne Greene

VIRON POLKA
(Estonia)

SOURCE: June Schaal learned this couple dance in Helsinki from Olli Ahlsted, a physical education instructor. Estonia is near the border of Finland and is now in Russian hands. Viron means Estonian.

MUSIC: Record: Express #236

FORMATION: Couples in a double circle in closed pos.

STEPS AND
STYLING:

Polka*, Walk* Bleking Step Variation (4 meas): With a low jump extend R fwd, ball of ft on the floor (meas 1, ct 1). Jump reversing ft so that L is extended fwd (meas 2, ct. 1). Reverse ft with 4 fast jumps extending RLRL fwd (meas 3, cts 1, 2 and meas 4, cts 1,2).

Cross Polka: Hop L (ct & of preceding meas), step R across in front of L, twisting body slightly to L (ct 1), step L in place in back of R (ct &), step R in place in front of L (ct 2). Next step begins crossing L in front of R. The style is gay and flirtatious throughout. Steps are described for M, W dances counterpart unless otherwise specified.

MUSIC: 2/4

Measures

1 note	Introduction
A	I. <u>TURNING POLKA</u>
1-8	Dance 8 polka steps turning CW and progressing LOD. M start with hop R.
B	II. <u>FACE TO FACE AND BACK TO BACK</u>
9-16	Facing LOD, W to MR, inside hands joined at shoulder height, outside fists on hips, dance 8 polka steps LOD, face to face on the first polka, then turning back to back, etc. throughout.
A	III. <u>KNEE BENDS AND CLAPS</u>
1	Face ptr, M back to ctr, W with fists on hips, M arms folded and held high across chest. Keeping ft and knees together and back straight, bend knees sharply (ct 1), straighten (ct 2).
2	Clap own hands 3 times (cts 1, & 2).
3-4	With free fists on hips, shake first the R forefinger at ptr three times (meas 3, cts 1, & 2) and then L forefinger three times (meas 4, cts 1, & 2).
5-8	Repeat action of meas 1-4, Fig III.

VIRON POLKA (CONT'D) Page -2-

B IV. BLEKING STEP

9-16 With fists on hips dance 2 Bleking step variations.

A V. STAR

1 Face ptr, clap own hands twice (cts 1, 2).

2-4 Both starting with hop on R, dance 3 polka steps in a R hand star turning CW. Keep palms and elbows together in star, outside fists on hips.

5-8 Dance 4 polka steps back to place in a L hand star turning CCW.

B CROSS POLKA

9-12 Face ptr, W fists on hips, M arms folded and held high across chest. Dance 4 cross polkas in place, both starting with hop L.

13-14 Dance 2 polka steps bwd away from ptr.

15 Take 2 walking steps (RL) twd ptr (cts 1,2)

16 Take 3 quick steps RLR (cts 1, &2) to finish in varsouvienne pos. facing LOD.

A VII. VARSOUVIENNE POLKA

1 Both step L fwd LOD (ct 1), touch R beside L (ct 2).

2 Step bwd R (ct 1), touch L beside R (ct 2).

3-4 Dance 2 polkas fwd LOD.

5-8 Repeat action of meas 1-4, Fig VII.

B VIII. CLAP, POLKA AWAY AND TOGETHER

9 Face ptr, M back to ctr, Clap own hands twice (cts 1,2).

10-12 W fists on hips, M arms folded across chest, dance 3 polkas bwd away from ptr. Start hop on MR.

13-16 Repeat the claps and polka steps dancing twd and passing ptr by R shoulder to finish almost back to back, looking over R shoulder at ptr.

A 1 W repeat clap, M stamp L heel twice instead of clapping (cts 1,2).

2-4 Dance 3 polka steps bwd away from ptr.

5-8 W repeat clap, M stamp R twice, and dance 3 polka steps fwd twd ptr. to join inside hands to repeat the dance.

Fig II thru VIII are repeated before Fig IX Finale

IX FINALE

B 9-16 Repeat action of Fig. II.

A 1-8 Repeat action of Fig I twice, dancing 16 polka steps any place on the floor.

9-16

1964 SANTA BARBARA FOLK DANCE CONFERENCE

Presented by Anatol Joukowsky

DETVA CZARDAS
(Slovakia)

- SOURCE: Detva Czardas comes from the Detva Valley in Slovakia. It was learned by Anatol Joukowsky from F. Fusseger in Bratislava in 1938.
- MUSIC: Record: Czardas from Detva 45rpm Special recording. Dance is in 4/4 and 2/4 meter. Intro and 1st part have no meter.
- FORMATION: Can be done by cpls or one M and 2 W. Either way, M is in inside circle with back to ctr. W are in outer circle facing their ptr. M join hands in their circle and W do same in their circle.
- STEPS: Double Czardas: Step to R with R (ct 1). Close L to R, bending knees (ct 2). Step to R with R (ct 3). Close L to R, bending knees (no wt) (ct 4). Next step would start to L with L.

Measures
no meter

Pattern

Introduction. This is instrumental. Stand in place.

I. Walking

There is still no meter structure so reference will be made to the musical phrase.

- Phrase I Circles walk to own R.
- Phrase II Circles walk to own L. Ptrs are again opp.
- Phrase III M offers R arm to ptr. If M has 2 W, he steps between them and offers both an arm. All walk CCW and wheel CCW at end of phrase.
- Phrase IV All walk CW. At end of phrase, M turn 1/4 R to face ^{away from} ctr. W step to ^{cut} inside to face ptr, ~~with back to ctr.~~ If in cpls, assume shoulder-waist pos. If a trio, make small circle by grasping adjacent forearms.

4/4 meter

II. Czardas, Clicks and Walk

- 1-2 Double Czardas to own R and L. ^{away from}
- 3 Beg R, 1 Double Czardas, moving ~~to~~ ctr. M go fwd. W back up.
- 4 Moving away ^{and} ~~from~~ ctr, step $\frac{1}{2}$ (ct 1), $\frac{1}{2}$ (ct 2), close $\frac{1}{2}$ to $\frac{1}{2}$ (ct 3). Hold ct 4.
- 5 Moving to own R, step R (ct 1). Cross L behind R (ct 2). With a little jump, take stride pos (ct 3). Click heels together (ct 4).
- 6 Repeat action of meas 5 but start with L and move to L.
- 7-10 Repeat action of meas 5-6 two more times.
- 11-12 Beg L, circle CW with 7 walking steps. End with click of heels. No. of circles is up to cpl or trio but try to end where you began.

DETVA CZARDAS (CONT'D) Page -2-

- III. Walking
- Phrase V M again offers arm to W and repeat action of Phrase III and
 Phrase VI IV. End in a single circle, W to R of ptr. If a trio, M is
 between his W. All hands joined.
Repeat action Fig II
There is now a break and a change in the music.
- IV. Circling ~~CW~~ CW
- 2/4 meter
 1 Step to L side on ball of L ft (ct 1). Step flat on R in
 front of L, bending knees (ct 2).
 2-4 Repeat action of meas 1 (Fig IV) three more times (4 in all).
 5-6 Beg L, take 4 running steps CW.
 7-18 Repeat action of meas 1-6 (Fig IV) two more times.
- V. Kick Step
- 1 Step on R, bending L knee so L ft is under body (ct 1). With
 a little hop, extend L straight fwd or a little in front of
 R (ct 2).
 2 Repeat action of meas 1 (Fig V) but step on L and bend R
 knee.
 3-4 Repeat action of meas 1-2 (Fig V).
 5 Moving away from ctr, step R (ct 1), L (ct 2).
 6 Close R to L (ct 1). Hold ct 2.
 7-12 Repeat action of meas 1-6 (Fig V) but on meas 11-12 move twd
 the ctr.
 13-36 Repeat action of meas 1-12 (Fig V) two more times.
- VI. Circling ~~CW~~ CW
- 1-18 Repeat action of Fig IV except on the last 4 running steps
 (meas 17-18) M bring W in twds ctr. ~~to take same pos as at
 end of Phrase IV~~ (W have backs to ctr). Both cpls and
 trios take forearm hold.
- VII. Kick Step
- 1-24 Repeat action of Fig V meas 1-24 with one adjustment. On
 meas 5-6 M moves away from ctr so W must move fwd. When
 M moves fwd, W back up. Cross kicking ft over supporting
 ft as much as is necessary to avoid kicking others.
 25-35 Repeat action of Fig IV, meas 1 eleven times. Cpls may
 change to shoulder-waist pos.
 36 Jump to stride pos (ct 1). Click heels (ct 2).

Notes by Ruth Ruling

1964 SANTA BARBARA FOLK DANCE CONFERENCE

Presented by Anatol Joukowsky

ERGENSKO ORO
(Macedonia)

- SOURCE:** This is a man's dance from the Ohrid Lake region of Macedonia. It was learned by Anatol Joukowsky in Ohrid in 1932 and was adapted by him to fit the music of S. Hristic, "The Legend of Ohrid Lake".
- RECORD:** Jugoton LYP 25
- FORMATION:** Dancers in a broken circle with hands joined and held shoulder height. The R hand supports the L hand of the dancer to the R.
- MUSIC:** This oro is in 9/16 and 13/16, alternating 1 meas of each. This 9/16 meter consists of 2/16, 3/16, 2/16, 2/16 so that 4 beats are felt with no 2 being longer. The 13/16 meter consists of 2/16, 3/16, 2/16, 2/16, 2/16, 2/16 so that 6 beats are felt with no 2 again being the longer. The meas will be written in cts with ct 2 being underlined to note that it is of longer duration. The Introduction only has a meas of 11/16 consisting of 2/16, 3/16, 2/16, 2/16. This will be written as 5 cts with ct 2 being underlined.
- STEPS:** Basic Step I (9/16): Step R to R side (ct 1). Step L across in front of R (ct 2). Step R to R side (ct 3). Step L across behind R (ct 4).
Basic Step II (13/16): Step R to R side (ct 1). Hop on R, starting to cross L over R (ct 2). Step L in front of R (ct 3). Step R to R side (ct 4). Step L in front of R (ct 5). Hop on L, placing R ft behind L leg (ct 6).

<u>Measures</u>	<u>Pattern</u>
3 meas	Stand in place. This is a meas each of 9/16, 13/16, and 11/16. Count (to yourself) 1, <u>2</u> , 3, 4 - 1, <u>2</u> , 3, 4, 5, 6 - 1, <u>2</u> , 3, 4, 5.
1 (9/16)	Facing a little L of LOD, dance Basic Step I, moving in LOD.
2 (13/16)	Continuing, dance Basic Step II.
3-8	Repeat action of meas 1-2 three times.
9-10	Turning to face ctr, dance one Basic Step and one Basic Step II twd ctr.
11-12	Moving away from ctr (back up), dance one Basic Step I and one Basic Step II.
	Repeat these 12 meas of dance until the end of the music.

*End of Dance is as follows
Do basic Step I & II, but in Step II R ft (ct 4) is placed
on floor as ft is raised (ct 7)*

1964 SANTA BARBARA FOLK DANCE CONFERENCE

Presented by Anatol Joukowsky

OUR KATIA
(Russia)

SOURCE: Our Katia is a horovodnaya pliaska or circle dance.

MUSIC: 2/4 meter Special recording

FORMATION: Closed circle, no ptrs. Hands joined and held down.

STEPS: Russian Polka: Step fwd on heel of L ft (ct 1). Close R to L (ct &). Step fwd on heel of L (ct 2). Repeat of step beg R.

<u>Measures</u>	<u>Pattern</u>
20 meas	Introduction. Dance starts with the vocal.
1-2	Beg L, dance 2 Russian Polkas to L (RLOD).
3-4	Continuing, walk 4 steps (L,R,L,R).
5-6	Repeat action of meas 1-2.
7	Walk 2 steps (L,R) in RLOD.
8	Step L in RLOD but turn to face ctr (ct 1). Step R twd ctr (ct 2).
9	Stamp L beside R (no wt) (ct 1). Step L twd ctr (ct 2).
10	Stamp R beside L (no wt) (ct 1). Step bkwd on R twd orig pos. (ct 2).
11-12	Continuing L,R,L back up to orig pos. Step R twd ctr (meas 12, ct 2).
13-16	Repeat action of meas 9-12.
17	Repeat action of meas 9.
18	Stamp R beside L (no wt) (ct 1). Release hands, extend arms to sides, L high and R low, palms out and elbows straight. Starting to make a 3/4 circle CW, step R (ct 2).
19-20	Continuing the 3/4 circle CW to reform circle of orig size, step L,R,L. Stamp ^R in RLOD (meas 20, ct 2) and rejoin hands to start dance again.

NOTE: Dance is written to conform to the musical structure. When dancing it, the first part seems to end on ct 1 of meas 8.

The second part seems to start on ct 2 of meas 8 and end with the 3/4 CW circle having 5 steps. When cueing the dance, it might be convenient to use a dance ct that starts again on ct 2 of meas 8.

Variations for Our Katia may be done at any time by any of the dancers without disturbing others.

Variation I

No change up through meas 8, ct 1.

Small leap on R twd ctr (meas 8, ct 2). Stamp L heel next to R (no wt) (meas 8, ct &). Small leap onto L twd ctr (meas 9, ct 1).

Stamp R heel next to L (no wt) (meas 9, ct &). Bigger leap onto R twd ctr (meas 9, ct 2). Step L next to R (meas 9, ct &).

OUR KATIA (CONT'D) Page -2-

Stamp R next to L (no wt) (meas 10, ct 1).
 Dance continues as in orig from meas 10, ct 2 through
 meas 12, ct 1. Do variation as given above for meas 12,
 ct 2 through meas 14, ct 1. Use also for meas 16, ct 2
 through meas 18, ct 1. In other words this is a variation
 to be used when moving twd ctr of circle.

Variation II

To be used when backing away from ctr. Dance same as orig
 through meas 10, ct 1.

Moving back to orig pos, step R (meas 10, ct 2), step L
 (ct &), step R (meas 11, ct 1), step L (ct &), step R
 (ct 2), step L (ct &). Stamp R next to L (no wt) (meas 12,
 ct 1). Actually 6 little steps and a stamp. Use also for
 meas 14, ct 2 through meas 16, ct 1.

Variation III

Same as Variation I, only done backing up (meas 10, ct 2,
 thru meas 12, ct 1).

Notes by Ruth Ruling

Variation IV - Russian Polka Steps
 The leader will yell Pa Sho and then ~~break~~ brake
 the circle, using the basic step, and serpentine
 until music ends. This is done toward end of
 music.

Note: - When doing the basic Russian Polka Steps, you should
 lean slightly to left when leading with L Ft, & lean to R
 when leading with R Ft.

1964 SANTA BARBARA FOLK DANCE CONFERENCE

Presented by Oliver "Sonny" Newman

BALLOS

(A Greek Couple dance starting in line)

As taught and danced by Oliver
"Sonny" Newman at Folk Dance Center,
New York City.

- RECORD: Folkraft 1463A
- FORMATION: (1) Line of couples, M holding W's R hand in his L.
(2) M w/back to center and facing W.
(3) Both moving frwd in LOD, M holding W's L hand in his R.
- METER: 2/4 Counted as Slow, Quick, Quick.
- PHRASING: 4 Measures of 2/4 repeated 3 times.
- SOURCE: Learned in Athens from a demonstration group performing at the Summer Folk Dance Festival and arranged to fit this record music by Sonny Newman.
- STYLE NOTE: The style of this Ballos is very bouncy, unlike the usual very smooth Ballos. Each 1st count of a measure should be preceded by an upbeat or a hop on the supporting foot such as is frequently seen in the end of the first measure of a Syrto. The other 2 counts should be very bouncy running steps. (The upbeat described is accomplished thusly as is shown in the diagram below. Don't listen for it, just know where to do it.)

		(long)	(short)	(short-hop)	
Meas.	Cts	1	2	& a	1 etc.
	Stps	R	L	R, Hop R	L etc.

Handkerchief should be used by M & W. Hands are held at shoulder level unless otherwise specified. Names of steps are for identification while teaching.

Step 1 (Syrto w/turn)

Phrase	Meas.	Cts.
1	1	(1) Step R to rt. (2) Cross L behind R. (&) Step R to rt.
	2	(1) Cross L in frt R. (2) Step R to rt. (&) Step L to rt.
	3	(1) Step R to rt. (2) Cross L over R. (Leave R hover over its position) (&) Rock R back to place.

(Stop Movement in LOD and do this step in place)

BALLOS (CONT'D) Page -2-

(NOTE: The preceding is the usual pattern for Kalamatiano or Syrto measures 1 - 3.)

Phrase	Meas.	Cts.
	4	(1) Step L to lft. (Starting to turn lft.) (2) Cross R over L. (Continuing turn to lft.) (&) Step L. (Finishing turn to L.)

NOTE: The body should incline to rt. and the turn should set you up for a natural move into ct. I of the next measure. Although the turn is to the left it should not stop the flow of movement to the right.

The preceding completes one musical phrase of the dance. It is repeated twice more with the exception of measure 4, phrase 3, in which the man only varies the step by turning 1/2 so that his back is to the center of the circle and he is in front and facing the women. Thus:

3	4	(1) Step L to lft. (2) Step R across left (Turning 1/2 turn) (&) Step L beside R (M is now facing W)
---	---	--

Step II (Balance w/do si do) (Partners facing, M's backs to center)

This step is a combination of 2 steps and takes 6 phrases of music to complete the step 3 times instead of 3 phrases.

Phrase	Meas.	Cts.
1	1	(1) Step R to rt. (2) Cross L over R (Leave R hover over position) (&) Rock R back to place.
	2	(1-2) Execute turn as described for meas. 4 of Phrase II, Step 1.
	3	(1) Step frwd twds ptnr R. (2) " " " " L. (Leave R hover.) (&) Rock back on R.

This step should bring the partners so that rt. hips are more or less adjacent. Rt. arm and hand extended across, but not touching, partner's middle. Left arm slightly above shoulder level and extended out.

	4	(1) Step L back from ptnr. (2) Step R " " " (&) " L next to R.
2	1	(1) Step frwd twds ptner R. (2) " " " " L. (&) " " passing ptner R.
	2	(1) Step L frwd past ptnr. (2) Step R turning to left. (&) Step L completing 1/2 turn to left. (Partners are now

BALLOS (CONT'd) Page -3-

facing w/W's back to circle center.

3-4 Repeat measures 1-2 of phrase 2, step II exactly.

Partners are once again facing each other w/M's back to center.

Repeat Phrases 1 & 2 of Step II twice more exactly.

Step III (Rocking step)

Women hold handkerchief by two opposite corners just below eye level. Play with it flirtatiously moving it back and forth in front of the face while the Men hold same corners of their handkerchiefs behind their necks. (This play with the kerchiefs is not typical of Greek girls, but is done in imitation of Turkish girls. Therefore it seems there is no definite style and may be loosely interpreted by the dancer.

Phrase	Meas.	Cts. (Both ptrns move in LOD)
1	1	(1) Step R (W to their rt M cross R to lft.) (2) Step L (Letting the body swing slightly w/step.) (&) Step R.
	2	(1) Step L (Continuing in LOD.) (2) Step R. (&) Step L.
	3	Same as Measure I.
	4	(1) Drop w/slight knee bend onto both feet. (2) Step R (straightening up). (&) Step L.
2	1	Girls repeat Phrase 1. Men do the following: (1) Drop to full knee drop on both feet. (2) Come up onto L. (&) Cut R across L taking weight.
	2-4	Repeat Meas. 1
3	1-4	Men and Women repeat Phrase 1 of Step III.

NOTE: The Men come out of Phrase 2, Step III with L foot free instead of R. Start Phrase 3 with L and don't do the drop on Measure 4 of Phrase 3. This sets the Men up for the next step with his L free which is correct.

Step IV (Turning step. Step is described for Women. Men do oppos)
(Both start moving in LOD)

Phrase	Meas.	Cts. (M start w/L, W w/R)
1	1	(1) Step R to rt. (2) Cross L behind R. (&) Step R to rt.

BALLOS (CONT'D) Page -4-

Phrase	Meas.	Cts.
	2	Execute 2 turns using all cts of meas 2 and ct. 1 of meas 3. (1) Cross L over R (Start turning rt.) (2) Step R (Cont. turning rt.) (&) Step L (Cont. turning rt.)
	3	(1) Step R to rt. (This step finishes the 2 turns.) (2) Cross L over R. (Partners are facing each other and the result of meas 3 is the usual cross over as done in meas 3 of step 1, Ph 1, Step I.) (&) Rock back R.
	4	(L) Touch L to L. (Take no wt. and hold cts. 2, 2&).

2 Reverse Phrase 1 and travel counter LOD. NOTE: The M is now doing what is described in Phrase 1 for the W, and she is reversing it.

3 Repeat Phrase 1 with the exception of the fourth measure in which the M move into line ahead of W to start dance from beginning thusly:

Meas.	Cts. (MEN)
4	(1) Step R frwd to rt side of W. (2) Step L turning rt into place beside W. (&) Hold this count w/no change of wt.

(WOMEN)	
(1)	Touch L (Take no wt.)
(2)	Step L.
(&)	Hold wt on L.

At this point both ptrs are free with their R R foot to begin the dance over. It is repeated exactly until you come to meas. 4, phrase 3, of step IV. At this point instead of the dance starting over you go into another step which is done thusly:

Back at STEP IV

Phrase	Meas.	Cts. (MEN)
3	4	(1) Step R in place. (2) Step L in place. (&) Hold R free.

(WOMEN)	
(1)	Touch L to L.
(2)	Step L to L.
(&)	Hold, R free.

Man remains in center. Takes W's L hand in his R.

Step V (Promenade)

Phrase	Meas.	Cts. (Both) (Move frwd in LOD)
1	1	(1) Step R frwd. (2) Step L frwd. (&) Step R frwd.

BALLOS (CONT'D) Page -5-

Phrase	Meas	Cts
	2	Repeat Meas. 1, ftwk continuing in LOD, alternate ftwk.
	3	Repeat Meas. 1.
	4	W turns 1/2 turn to rt. stepping as in meas. 2 ending w/bk to LOD. M repeat meas. 2. (Hands are not held during turn.)
2	1-3	Do exactly the ftwk as in Phrase 1, Meas. 1-3. M hold their rt hand across W's middle not touching. Left hand extended at shoulder level. M move frwd, W bkwd.
	4	(1) Step L beginning 1/2 turn rt. (2) Step R completing the 1/2 turn. (&) Step L. (Now M have back to LOD and W are facing.)
3	1	(1) Step R. (M move back in LOD, W move fwd in LOD) (2) " L. (&) " R.

2 Reverse ftwk.

3 Repeat Meas. 1

4 Reverse ftwk. Meas. 1

Step VI (Ending) Only one Phrase. (Man in lead take W's R hand in his L as in beginning of dance.)

Phrase	Meas.	Cts.
1	1-3	Same as Meas 1-3 of Phrase 1, Step 1.
	4	(1) Step L to lft. (2) Cross R behind L touching R toe to floor and taking no weight. (&) Hands raise in air, feet stay as in ct. 2.

1964 SANTA BARBARA FOLK DANCE CONFERENCE

Presented by Oliver "Sonny" Newman

EPIRIOTIKO KALAMATIANO

KARAPATAKI
(Epirus-Greece)

SOURCE: Learned in Greece by Sonny Newman.
 RECORD: Slavjani 1002
 FORMATION: Line holding hands at shoulder hgt. Men's dance.
 METER: 7/8, counted Slow (3/8), Quick (2/8), Quick (2/8).

<u>Meas.</u>	<u>Pattern</u>
	<u>STEP I</u>
1	Step R to R swinging L in high arc from L to R. (entire meas.)
2	Step L across R swinging R frwd in high arc ending arc w/ small CCW vertical circle.
3	Step R to R, raise L up across to R as in Hassapiko but higher
4	Step L to L raising R in frnt of L and swinging it to R ending w/CW vertical circle.

	<u>STEP II</u>
1	Step R to R (S), describe a large arc on floor w/L from its orig. pos. to pos. in frnt and to L side of R with toe touching floor, heel up (Q,Q).
2	Step L ft to R crossing in frnt of R (S), describe and arc w/R from orig pos to pos at R side of L. Toe on floor heel up (Q,Q).
3	Step R to R (S), raise L leg high in frnt and slightly crossing R (thigh parallel to floor, calf hanging freely from knee. (Q,Q).
4	Step L to L (S), raise R leg across L then swing it in and arc CW so that R ft comes to L knee (Q,Q).

VARIATION

On measure 4 when swinging R leg in arc to R, lead the body
into a CW turn. Everyone makes one turn CW dropping
handholds but keeping hands at shoulder level.

STEP III

Probably the development of the Kalamatiano into the most
popular Greek dance today happened when the dancers began
stepping on all of the predominant beats instead of only
the first beat of the meas. The musical emphasis changed
also giving a more definite "3 beats" per meas.

Facing to R in line

1	Stp R fwd (S), rock back on L (Q), rock fwd R (Q).
2	Stp L fwd (S), Rock back on R (Q), rock fwd L (Q).
3	Face ctr, stp R to R (S), cross L in frnt of R (Q), rock bck R (Q).
4	Face ctr, stp L to L (S), crss R in frnt of L (Q), rock bck L (Q).

EPIRIOTIKO KALAMATIANO KARAPATAKI (CONT'D) Page -2-

- Step IV (in full squat)
- 1 Stp R to R swing L across R (L should be lying on floor on side of leg from the knee to the ft.)
 - 2 Stp L across R to R swinging R across L (R lying on flr from knee to ft.)
 - 3 Stp R to R extend L straight out to R (not touching floor - like Russian "Pryssiadka").
 - 4 Stp L to L extending R as L was in meas. 3

1964 SANTA BARBARA FOLK DANCE CONFERENCE

Presented by Oliver "Sonny" Newman

KRITIKOS SYRTO
(Crete)

SOURCE: Variations learned by S. Newman from T. Petridis, the ethnic groups in New York and some in Athens.

MUSIC: Record, Slavjani 1002

FORMATION: Line (Variations are indicated by leader's call).

METER: $2/4$ [↑] Lines should be composed of 5 or 6 people... hands held shoulder ht, elbows somewhat bent.Meas. PatternBASIC STEP

- 1 Brush L ft fwd and in an arc to the L passing behind R ft (ct. 1), Step L behind R (ct. 2), step R to R (ct. &).
- 2 Step L across in front of R (ct. 1), step R to R (ct. 2), step L to L (ct. &).
- 3 Step R across in front of L, leave L hovering over place (ct. 1), rock back on L (ct. 2), step R to R (ct. &).
- 4 Step L across in front of R (ct. 1), close R bsde L (ct. 2).

VARIATION I (Hesitation) (done in place of meas. 2 only)

- 1 Same as Basic.
- 2 Step L across in front of R (ct. 1), carry R in arc around L from R to L with slight knee flex or impulse on (cts. 2, &).
- 3-4 Same as Basic.

VARIATION II (Travel)

- 1 Same as Basic
- 2 Step L across in front of R (ct. 1), step R twd ctr of circle (ct. 2), step L twd ctr (ct. &).
- 3 Step R twd ctr rising on ball of ft, bring L up bhnd R calf (ct. 1), step L bck from ctr (ct 2, step R bk from ctr (ct. &).
- 4 Step L bk frm ctr (ct. 1), clse R bsde L (ct. 2).

NOTE: Variation II can be done traveling in LOD or RLOD by initiating the direction in meas. 2 (ct. 2) with the direction of the placement of the R ft.

VARIATION III (Cross-over or Cut)

- 1 Same as basic.
- 2 Step L across in front of R (ct. 1), hop on L, bringing R from back to frnt (ct. &), step R across in frnt of L (ct. 2), hop on R, bringing L from bck to front (ct. &).
- 3 Repeat action of meas. 2, Varia. III.
- 4 Repeat action of meas. 2, cts. 1. Close R beside L (ct. 2).

VARIATION IV (Box)

- 1 Brush L ft. fwd (ct 1), stp frwd onto L (ct 2), stp R fwd (ct. &).
- 2 Step L frwd (ct. 1), cross R over L to L (ct. 2), step L to L (ct. &).
- 3 Step R to L (ct. 1), Step L bck frm ctr (ct. 2), step R bck from ctr (ct. &).
- 4 Step L bck from ctr (ct. 1), close R to L (ct. 2).

1964 SANTA BARBARA FOLK DANCE CONFERENCE

Presented by Oliver "Sonny" Newman

PAPURI

Pronunciation: (Pah-poo-ree)SOURCE: Turkish Line Dance from Bitlis City.
Cavit Kangoz as taught at Folk Dance Center of New York City.

RECORD: Folk Dancer MH 016

FORMATION: Alternating M - W, Hands on shoulders

METER: 4/4

Introduction: A long introduction is played during which the line sways with the leader leaning very low to one side then to the other. Feet are in a wide stance, enabling the dancers to nearly touch the floor with their knees. As the drum beats become predominant the line straightens upright to begin the dance at the leader's indication.

<u>Meas.</u>	<u>Cts.</u>	<u>Step</u>
<u>STEP I (Slow part)</u>		
1	1	Step R to R,
	2	" L to R across R,
	3	" R to R,
	4	Hold wt on R, L ft up behind,
2	1	Hopping on R touch L heel on ct., in frnt of R, body to
	2	Leap onto L turning to face center,
	3	Touch R heel diag in frnt and to L of L ft.
	4	Pivoting to R on L ft, touch R heel again slightly to R of last touch.
3	1	Pivoting to R on L ft, touch R heel again slightly to R of last touch,
	2	Hold
	3	Clse R to L,
	4	Hold.

<u>STEP II (Fast)</u>		
1	1	Hop on L, at same time touch R heel to floor,
	&	Stp R to R,
	2	Stp L across R,
	3	Spring to R onto both balls of feet,
	4	Hop, landing on R on ct, L ft up behind,

2-3 SAME AS MEAS. 2 & 3 of Step I.STEP III (Fast W/claps - hands not held)

Do same ftwk as Step II. Clap hands on cts 1, 3, 4 of meas. 2 and cts. 1, 3 of meas. 3.

PAPURI (CONT'D) Page -2-

STEP IV (Fast-Hands on shoulders)

- 1 Same as Step II meas. I.
- 2 1 Hopping on R, touch L heel on ct. in frnt of R, begin
inclining body to L
- 2 Leap onto L turning to face center.
- 3 Hop on L to L, large hops, R extended low to R, not touch
- 3 1 " " " " " " " " " " " "
- 2 Hold wt on L, bounce twice on L.
- 3 Close R to L,
- 4 Hop on L bringing R up behind in preparation to repeat.

1964 SANTA BARBARA FOLK DANCE CONFERENCE

Presented by Oliver "Sonny" Newman

PENTAZALIS
(Crete)

- SOURCE: Summer Festival in Athens, and Cretean ethnic groups in New York.
- MUSIC: Record: Folkraft LP 3, Side 2, Band 2 "Greek Folk Dances".
- FORMATION: Line. Leader calls out variations.
- METER: 2/4 (despite the complex appearance of Pentazalis, it fits into a very ordinary rhythmical breakdown of Slow, Quick, Quick.)

MeasuresPatternI. BASIC STEP

- 1 Step L (ct 1). Bring R ft up across in front of L rising on the ball of the ft (ct 2). Lower L heel (ct &).
- 2 Step R (ct 1) (bringing L ft close to R). Step L to L (ct 2). Step R across slightly in front of L (ct &).
- 3 Step L in place (ct 1). Step R to R (ct 2). Close L to R (ct &).
- 4 Step R to R (ct 1). Bring L up across in front of R rising on ball of R (ct 2). Lower R heel (ct &).

II. VARIATION #1 - LEAP ACROSS

- 1-2 Repeat action of Fig I, meas 1-2.
- 3 Step L in place (ct 1). Making a small arc, leap onto R ft. to R (ct 2). Step L across in front of R (ct &).
- 4 Repeat action of meas 4, Fig I. Basic.

III. VARIATION #2 - BRUSHES

- 1 Repeat action of meas 1, Fig I, Basic.
- 2 Step R to R (ct 1) extending L slightly fwd of R. Step L in place, extending R (ct 2). Step R in place, extending L (ct &).
- 3 Step L in place extending R (ct 1). Step R in place extending L (ct 2). Step L in place (ct &).
- 4 Repeat action of meas 4, Fig I. Basic.

IV. VARIATION #3 - POLKA

- 1-2 Repeat action of meas 1-2, Fig I. Basic.
- 3 Step L in place (ct 1). Hop of L moving R slightly bwd diag (ct &).
- 4 Step R to R (ct 2). Close L to R (ct &).
- 4 Repeat action of meas 4, Fig I. Basic.

V. VARIATION #4 - TRAVELLING

- 1 Repeat action of meas 1, Fig. I. Basic.
- 2 (Steps in meas 2 and 3 are very small) Step R to R (ct 1). Cross L behind R (ct &). Step R to R (ct a). Step L behind R (ct 2).

PENTAZALIS (CONT'D) Page -2-

<u>Measures</u>	<u>Pattern</u>
3	Small leap on R to R (ct 1). Step L in front of R (ct &). Step R to R (ct a). Step L in front of R (ct 2).
4	Repeat action of meas 4, Fig I. Basic.

1964 SANTA BARBARA FOLK DANCE CONFERENCE

Presented by Oliver "Sonny" Newman

TEMILAV

(Turkish line dance - M & W alternating)

SOURCE: Taught by Cavit Kangoz at The Folk Dance Center of New York City.

MUSIC: Slavjani 1001

METER: Slow part - 2/4, Fast part - 4/4.

STYLE NOTE: Little fingers are held throughout dance.

PART I (Forearms straight frwd from elbows - elbows close to side.)

Meas.	Cts.	STEPS	ARMS
1	1	Step R to R, - - - - -	Arms swing R from elbows.
	&	Clse L to R, - - - - -	" " L " "
	2	Step R to R, - - - - -	" " R " "
	&	Swing L low across R, - - - - -	Hold arms to R.
2	3	Step L in place - - - - -	Move arms to Center.
	&	Point R slightly back, - - - - -	Hold arms cntr.
	4	Step back on R, - - - - -	Extend arms frwd from shoulder
	&	Fall back on R, taking- - - - -	Bend arms sharply so that
		all of wt. quickly.	hands are close to shoulder.
		R knee bent, L toe touching	
		frwd, L knee bent.	

PART II (Keep body and legs in the same relationship as in ct. 4& of Part I throughout cts. 1-3 of Part I.)

		STEPS	ARMS
1	1	Step frwd L, - - - - -	Thrust arms straight down
	&	Clse R displacing L,	from shldr, hold down
	2	Step frwd L,	very stiff throughout
	&	Clse R displacing L,	cts. 1-3.
2	3	Stp frwd L,	
	&	Hold wt bringing R close - - - - -	Swing arms frwd from shoulder.
		to L but take no wt.,	
		straighten body,	
	4	Tch R slightly frwd, - - - - -	Arms swing down to side.
	&	Hop L, raising R knee. - - - - -	Swing arms frwd from shldr.

PART III (Moving backward)

		STEPS	ARMS
1	1	Step R back, - - - - -	Arms swing down to side.
	&	Swing L frwd - - - - -	" " up.
	2	Step L back - - - - -	" " down.
	&	Swing R frwd, - - - - -	" " up.
2	3	Step R back, - - - - -	" " down.
	&	Swing L frwd, - - - - -	" " up.
	4	Step L back - - - - -	" " down.

TEMILAV (CONT'D) Page -2-

& Swing R frwd w/ control - - - - Arms swing to pos. to beg.
 preparing to start dance dance over.
 from beg.

FAST PART I (mtre 4/4, counted 1,2,3,4)

<u>Meas.</u>	<u>Cts.</u>	<u>STEPS</u>	<u>ARMS</u>
1	1	Touch R heel to R, Hop L, - - -	Arms are same as slow part
	&	Step R toe to R,	
	2	Cross L over R,	
	3	Step R to R,	
	4	Swing L across R,	
2	Same as Meas. 2 of slow part.		

FAST PART II (Same as slow part 2)VARIATION FOR FAST PART II

Instead of rocking frwd and back, stamp frwd with same foot with same foot per count as basic step. Knees in a low crouch, body erect from knees.

NOTE: During Fast Part II, basic and variation, a fast "shimmy" of the shoulders may be done.

FAST PART III (Same as slow part 3 except that a hop is done on the supporting foot as the free leg swings forward.

1964 SANTA BARBARA FOLK DANCE CONFERENCE

Presented by Oliver "Sonny" Newman

VARI HASSAPIKO
(Greece)

This Slow Hassapiko, or Sailors Dance, like many Greek dances, is based upon a form that is freely interpreted by the leader. The rest of the dancers in the line follow his lead by signals passed down the line through the touch of the hand to the shoulder of the next dancer. (This will necessitate a short line of 4 to 6 people). Infinite variations can be developed by the leader and it is not necessary to do what is called the "basic step". In fact, many Greeks who do this dance do not know the "basic step", but are so familiar with the form and the mood that they can dance to the music without reference to any definite step. This is the ideal towards which a folk dancer should strive; but without the inherent feeling of the music or style one needs to have something basic to refer to and build upon. The following descriptions for Vari Hassapiko, are merely steps that can be used as a guide until you, as the dancer, become familiar enough with the idiom to improvise with ease.

SOURCE: Bauzoukee taverns in the United States and Athens. S. Newman.

MUSIC: Record: Any Vari Hassapiko

FORMATION: Short line of 4 to 6 dancers with hands on shoulders.
Leader on R end of line.

STYLE: The music will determine the mood greatly and the style will be affected by it. Steps are slow, sharp, and tense. The body is generally bent fwd slightly.

<u>MEAS.</u>	<u>CT.</u>	<u>PATTERN</u>
		With body leaning slightly fwd from the waist.
1	1	Fall fwd onto L.
	&	Hold R behind slightly off floor, or tap behind L heel.
	2	Brush R in front of L.
	&	Swing R to back of L.
	3	Step R displacing L.
	&	Swing L in small arc to back to R.
	4	Step L, displacing R.
	&	Pull R back across L instep.
2	1	Step R to R, moving R.
	&	Step L to R, moving R.
	2	Step R to R, to face ctr.
	&	Pull L back across R instep sharply and lean fwd at the waist preparing for ct 1 of meas. 1.

The preceding completes the basic step. It may be repeated immediately as often as the leader wishes. Not infrequently, however, extra steps are added at this point, to complete the musical phrase of 2 meas. The following are 2 variations that you may use to fill the phrase:

VARI HASSAPIKO (CONT'D) Page -2-

(var 1)

- 3 Step on L lifting R behind slightly off floor.
 & Step back on R lifting L slightly off floor in front.
 4& Repeat

(var 2)

- 3 Place L heel on floor in front of R.
 & Tilt L toes to R.
 4 Tilt L toes to L.
 & Bring L back across R instep preparing for ct 1 of meas 1.

I would like to make a special note of the fact that each combination of steps described in this dance fits a phrase of music. It is not a rule that each step fit a phrase, but it is much more musical and more pleasing to the senses and is, therefore, easier to teach and to learn. The following are some variations that I have learned by dancing with the Greeks, and from teachers of Greek dancing.

VARIATION I

Meas. Ct. CROSS OVER WITH 3 DOUBLES AND 2 SINGLES
 This step following the last count of the basic is quite natural and begins the development of the dance very nicely.

- 1 1 Step L over R to R.
 & Close R to heel of L.
 2 Step L to R.
 & Bring R around in front of L in preparation to reverse direction of ct 1.
 3,&,4,& Repeat action of cts 1,&,2,&, with opp footwork.
 2 1,&,2,& Repeat action of cts 1,&,2,& of meas 1.
 3 Bring R over L and step on it.
 4 Bring L beside R and close on beat.

CROSS OVER WITH 2 DOUBLES AND 4 SINGLES

- 1 Repeat action of meas 1 in above pattern.
 2 Repeat action of meas 2, cts 3, 4 (single cross overs), beg L and do 4 single cross overs.

VARIATION II CROSS OVER - CENTER CROUCH

- 1 1 Step L over R to R.
 & Close R to heel of L.
 2 Step L to R.
 & Bring R around in front of L in preparation to move to ctr of circle.
 3 Step fwd R.
 & Close L to R.
 4 Step R bending with wt on R to a very low crouch. (L may touch floor behind R to maintain balance.)
 & Hold.
 2 1 Step L behind R and rise from crouch.
 2 Step R behind L.
 3 Step L behind R.
 4 Close R to L.

VARI HASSAPIKO (CONT'D) Page -3-

<u>Meas.</u>	<u>Ct.</u>	<u>VARIATION III SQUAT, AND THEN TURN</u>
1	1	Step L over R to R.
	2	Extend R leg, hip high, diag fwd R.
	3	Take wt on both ft <u>with R in front of L</u> in full knee bend.
	4	Stand, extending R again.
2	1	Take wt on both ft, <u>R behind L</u> , full knee bend.
	2	Stand, extending L.
	3	Wt on both ft, <u>L behind</u> , full knee bend.
	4	Execute CCW pivot in full knee bend.

I usually follow this with a Basic Step with stamp on ct 1.

<u>VARIATION IV</u>		
1	1	Jump to stride pos.
	2	Jump with ft together.
	3	Jump onto R ft, bending fwd at waist.
	&	Tap L toe far behind supporting R.
	4	Brush L ft fwd, straightening body.
2	&	Hold L ft in front of R a few inches off floor.
	1	Step L close to R side of R ft.
	2	Step R beside L.
	3	Step L close to R side of R ft.
	4	Step R beside L.

<u>VARIATION V</u>		
1	1	Jump to stride pos.
	2	Jump with L ft close across R.
	3	Turn 1/2 CW (let hands drop).
	4	Jump to stride pos (Put hands on shoulders).
2	1	Jump with L ft close across in front of R.
	2	Turn 1/2 CW (let hands drop).
	3	Rock wt onto L in front of R (hands on shoulders).
	&	Rock back on R.
	4	Close L to R.

1964 SANTA BARBARA FOLK DANCE CONFERENCE

Presented by Oliver "Sonny" Newman

W DOLINA
(Polish)

RECORD: Monitor 326 Slask Vol 2.

FORMATION: Couples facing each other (M with back to center)

METER: 4/4

STYLE: The most important thing for the Folk Dancer to remember about Polish Dancing is that it is accompanied by an air of flamboyance. The arm movements should be full sweeping, being grand. Don't hesitate to be "a little" balletic.

Introduction: Stand for four (cts.)

Meas. Pattern (Steps described for M - W do opposite)

1 Make 1/2 turn to be back to back. (Make all turns toward line of direction). (M) Step L (ct 1), Step R (ct 2), L (ct 3), Stamp R beside L (ct 4). Ptnrs now back to back.

2 Reverse footwork meas 1. (Ptnrs are now face to face again)

3 Repeat meas 1

4 Repeat meas 2

II Weaving forward figure Women move forward 4 positions while men stay in place. Then men move forward 4 pos. to partner. While moving forward weave diagonally to the inside and outside of circle as described below.

Women

1 (Moving to inside of man ahead) Step R (ct 1), Step L (ct 2), Step R (ct 3) brush L (ct 4). Greet man on (ct 4)

2 (Moving to outside of next man in LOD) Step L (ct 1) R (ct 2) L (ct 3), Brush R (ct 4)

3 Repeat meas 1

4 Repeat meas 2

Men

(Stay in place and greet girls as they move by)

1 Turning to face center of circle, step backward into partner's position. Step back onto L foot, R, L. R is extended w/heel on floor toe up (cts 1,2,3,4). As you step back sweep L arm in arc in front of body to a position high over head.

2 Turning to face outside of circle step forward into original position w/L foot extended, Right arm sweeps up greeting girl moving to outside of circle.

3-4 Repeat meas. 1 & 2 respectively.

NOTE: Women touch toe on floor on ct. 4, not heel. While turning from outside to inside, always face frwd in LOD -- NEVER RLOD.

Woman stay in place, M move forward.

W DOLINA (CONT'D) Page 2

Woman

1-4 Do as men did on previous 4 meas, but start on meas 1 turning to face outside of circle.

Men

1-4 Move forward starting to outside of circle. Start L and instead of brushing on ct 4, Stamp.

III Walk & brush while enlarging circle. Take hold inside hands. Use this step to enlarge circle by moving away from the center of the circle in a "Zig-Zag" pattern.

Man's back to center of circle, W facing center of circle.

1 Man start L - W start R. Take three steps LOD (Ct 1, 2, 3) on ct 4 close M-R W-L.

2 Man start R, W-L move RLOD. Retaining same handhold

3 Repeat meas 1

4 Repeat meas 2 but W give R hand to M on last ct of meas.

IV Double heel clicks and cross overs R hands joined.

Footwork same for M & W. Turn CW 4 meas and CCW for 4 meas.

1 Hop on R beating L heel to R heel while in air (ct. 1)

Repeat ct. 1 (ct. 2), Leap from R to L (ct. 3), Step R across in front of L (Ct. 4).

2-3 Repeat meas. 1 twice

4 Repeat cts 1-3 of meas 1, brush R ft to R to start momentum CCW and change hands (ct 4)

5-8 Reverse meas 1-4. On ct 4, meas. 8, open to face LOD.

V Walk forward and Separate

1 Walk forward in LOD 4 steps (cts 1-4) M start L, W-R.

2 Walk diag. forward in LOD, M twd center, W away from center. 3 steps (cts 1-3). Close free ft to supporting ft (ct 4), turning to move diagonally toward partner still moving fwd.

3 Reverse footwork meas 2 moving forward partner.

4 Repeat meas 2.

5 Repeat meas 3.

VI Walk and Slow Turn (inside hands joined)

1 M start L W-R walk fwd 3 steps (cts 1-3), Close free ft to supporting ft ct 4. and face each other retaining hand hold.

2 Retard in music M steps RLOD on R ft and draws L to R (cts 1-4). W steps RLOD with L and crosses R in front of L to do one slow turn under joined hands (cts 1-4). Music picks up in tempo.

VII Single heel clicks R arms around ptrns waist, R hips adjacent L arms in air.

3 Both hop on R and Click L heel to R (ct 1), Step L (ct &) Close R to L (ct 2).

4 Repeat meas 3.

5-8 Repeat meas 1-4.

W DOLINA (CONF'D) Page 3

Dance Repeats. The 4 counts of introduction are used now to close the circle. Partners take four steps toward center.

After doing the dance the second time through exactly as the first time do the following:

ENDINGMeas.

- (Step 1)
- 1 M start L and walk three steps directly toward center (ct. 1-3) stamp R (ct 4)
W start R and walk 3 steps directly away from cntr (ct. 1-3) stamp L (ct 4) turning to face cntr.
- 2 M start R turn $\frac{1}{2}$ CW turn in place 3 steps (ct. 1-3) stamp L (ct 4).
W start L walk 3 steps (ct 1-3) to original position, brush R ft frwd (ct 4).
- 3 M start L turn $\frac{1}{2}$ CCW turn 3 steps (ct 1-3), stamp R (ct 4).
W start R walk twd cntr to be at R side of ptr, 3 steps (cts 1-3), close L to R turning $\frac{1}{2}$ CCW to face out from center (ct 4).
- 4 Both walk out from center 4 steps (cts 1-4) (M start R, W-L).

ENDING (step II) (Circling each other CCW)

- 1-4 Use same ftwk as step V but individually without holding hands. The arms should swing out to be extended sideward at shoulder level on (ct 1), remain there (ct 2), drop down to a crossed position low in front of body on (cts 3-4).

On final two chords the M drops to L knee with L ft pointing back twd center of circle.

Women use the crossing of the L ft in front of the R to execute one CW turn and strike a pose facing the Man.

1964 SANTA BARBARA FOLK DANCE CONFERENCE

Presented by Oliver "Sonny" Newman

ZAGORITIKO
(Greece)

RECORD: "Songs and Dances of Epirus" T'aidonia A.H. LPl
 FORMATION: Hands held at shoulder level. Separate lines M-W
 METER: 5/8, Counted Q, Q, Q, S or 1, 2, 3, 4. Ct. 4 is underlined as it is longer (2/8).

MEASURESPATTERNW Styling

I

1 Touch L in front of R (ct 1), touch L to L side (ct 2)
 step L in front of R (ct 3), bring R up behind L so
 that R ankle is touching diag across back and inside
 of L leg (ct 4).

II

2 Face R, step R to R (ct 1), step L to R (ct 2),
 step R to R (ct 3), step L to R (ct 4). Hold R ft
 next to L ankle.

III

3 Face ctr, bring R around to step twd ctr of circle
 and drop the wt onto it heavily with slight knee
 bend (ct 1), step on L directly behind R (ct 2),
 step R back from ctr (ct 3), raise L almost straight
 knee in front of R (ct 4). (Accent on lift of (ct 4).

IV

4 Face R and walk bwd, step L to L moving diag back to
 the L (ct 1), step back R (ct 2), step back L (ct 3),
 close R to L (ct 4).

M Styling

1 Touch L in front of R (ct 1), lift L to L side (ct 2),
 step L in front of R (ct 3), bring R up behind L knee (ct 4).

2 Same step as for W.

3 ~~Same as for W (ct 1), same as for W (ct 2)~~
 Drop heavily onto R directly behind L (ct 3),
 stamp L and lift until thigh is parallel to ground
 (ct 4). *Raise on ball of l ft raising h knee high*

4 *Ct 1: with R knee still lifted, lower h heel (ct 2);*
 Same as for W. *step on R beside h (ct 3); tap h heel (ct 4).*

1964 SANTA BARBARA FOLK DANCE CONFERENCE

Presented by Oliver "Sonny" Newman

ZEYBEKIKO

(Greek solo or couple dance)

RECORD: RCA 47g 2146; Folkraft LP 3, side 2, band 6 - "Greek Folk Dances."

MUSIC: Any Zeybekiko will work. Preferably slow to moderate tempo.

METER: 9/8 (Count measures 1,2,3,4; 1,2,3,4,5.)

Meas.	STEP I BASIC (Remain facing center of circle or ptr.)		Steps
	Beats	Cts.	
1	1	(1)	Step R to rt. (approx 12" from L)
		(&)	Close L to R. (ball of L ft touching flr.)
	2	(2)	Hold position.
		(&)	Step L twds ctr of circle in front of R.
	3	(3)	Step on R on its previous floor spot.
4	(4)	Step L to lft (approx. 12" from R.)	
5-8	(1-4)	REPEAT ABOVE EXACTLY.	
9	(5)	Step R to rt.	

2 REVERSE ABOVE.Variation I Slow turn on second half.

On beats 8 & 9 a slow turn is very nice. Begin on the L (Ct 8) and complete on the R (Ct 9), Now do entire step to left.

Variation II Fast turn on first half.

A quick turn on Ct. 4, Step L doing a complete turn. Finish 1st measure either without turning or with Variation I.

STEP II CIRCLING (Done with or without a ptr.)

Start moving frwd from original spot. Make a circle as in a "do-si'do" and move bkwds into original position.

Meas.	Beats	Cts.	Steps
1	1	(1)	Step R frwd.
		(2)	Step L frwd.
	2	(&)	Close R to L (As in a two-step.)
		(3)	Step L frwd.
3	4	(4)	Step R (Cross R in frt of L to begin moving bkwds to place. If you do this with ptr, the step is like a "so-si-do". (Half turn is CCW)
		(1)	Step L diag bkwd to lft.
4	5	(2)	Step R bk.
		(&)	Clse L to R (As in a two-step)
5	6	(3)	Step R bkwd.
		(4)	Step L (More or less in place as you should now be in original position approx.)
6	7	(5)	Step R (Still hovering over orig. spot.)
		(1)	

2 REVERSE ALL STARTING NOW TO THE LEFT.

ZEYBEKIKO (CONT'D) Page -2-

STEP III (Rocking)

- Meas.
1 Step R to R (ct 1), step L across R (ct 2), rock back to R ft in its previous pos (ct &), step L to L (ct 3), step R to R (ct 4). Reverse above to L (cts 5-8), step R to R (ct. 9).
- 2 Step L to L (ct 1), step R across L (ct 2), rock back to L ft in its previous pos (ct &), step R to R turning CW (ct 3), step L completing one CW turn (ct 4). Reverse above to R (ct 5-8) turning CCW, step L to L (ct 9).

NOTE: A pattern should not exist for this kind of a dance, but to help folk dancers find their way into it I have arranged this sequence.

Pattern I	Basic step to each side
Pattern II	Variations 1 or 2 to each side
Pattern III	Fig II, Circling to each side
Pattern IV	Fig IV, Rocking

1964 Santa Barbara Folk Dance Conference

presented by William F. Pillich
Asso. Supervisor Physical Education
University of California, Los Angeles

It is my belief that as dance instructors we are concerned with efficient and good use of the body.

Factors that influence movement, such as:

- Law of gravitation
- Law of attraction and repulsion
- Law of resistance and yielding

should be related to human movement as dance skills are analyzed.

In addition, I believe that movement should be natural to the individual and not imitation; movements should have sequential action in which one movement flows into the other.

Especially in dance, if the mechanics of moving are right for the individual then the doing will "feel right" and real enjoyment and satisfaction will result.

So - in ballroom dancing instead of teaching a series of step patterns to be memorized - I believe in allowing the individual to explore different kinds of movement patterns and then help the learner to relate and compose these fundamental movements into popular ballroom dance forms.

There are, however, certain basic information and understandings necessary to assist the individual to "get the most out of his dancing." The following information is organized for economical purposes:

1. TIMING AND QUALITIES IN MUSIC.
(Ballroom dancing is primarily a movement interpretation of music)
How does a Waltz differ from a FOX-TROT?
How does the music determine HOW and WHAT dances should be done to it?
2. BASIC STEPS AND POPULAR VARIATIONS.
What are fundamental steps used in Ballroom dancing?
How can they be changed for variety?
How can I feel more at ease and comfortable while dancing?
3. LEADING AND FOLLOWING.
What are certain techniques in leading and following which are essential to good dancing?

An attempt is made in these notes to analyze selected ballroom dances in terms of TIME, SPACE, and ENERGY-QUALITY. - "To help you get the most out of ballroom dancing."

GENERAL INFORMATION

WHEN YOU HEAR DANCE MUSIC:

Listen for the pulse beats, they will be even and steady:

Listen for the accented beats, they will occur at certain intervals and are louder than other pulse beats;

Listen for the quality expressed, the instrumentation, the speed of pulse beats -- these will be clues which can be used to determine whether the music is Tango or Fox-Trot, etc. Many times the type of music is so subtle it is difficult to distinguish between rumba and cha cha cha.

Trying clapping or better still try walking on each pulse beat.

Take a longer step on the accented beat.

If every other beat is accented then you would count 1 2 1 2 1 2;

If every third beat is accented then you would count 1 2 3 1 2 3 1 2 3;

If every fourth beat is accented then you would count 1 2 3 4 1 2 3 4

(note in each case the first beat is accented);

If you take a step on every pulse beat you are walking as the steps would be steady and even.

Pulse beats might be combined into a rhythm pattern. This means in addition to accents some pulse beats are combined with other beats, as an example,

<u>J I N G L E</u>	<u>B E L L S</u>	<u>J I N G L E</u>	<u>B E L L S</u>
1 2	3 - 4	1 2	3 - 4
<u>quick</u> <u>quick</u>	<u>s l o w</u>	<u>quick</u> <u>quick</u>	<u>s l o w</u>

in this case there are really 4 beats in phrase j i n g l e b e l l s but the word b e l l s is equal to 2 beats. In dance this rhythm would be quick quick s l o w.

Other rhythms common to dance are:

1. 1 2 3 4 5 6 7 8
 step step step step step step step step
quick quick quick quick quick quick quick quick

2. 1 2 3 4 1 2 3 4
 step step s t e p step step step s t e p
quick quick s l o w quick quick s l o w

3. 1 2 3 4 1 2 3 4
 s t e p step step step s t e p step step
s l o w quick quick s l o w quick quick

4. cha cha cha rhythm is:

1	2	3 &	4	1	2	3 &	4	
step	step	st st	step	step	step	st st	step	
<u>slow</u>	<u>slow</u>	<u>q. q.</u>	<u>slow</u>	<u>slow</u>	<u>slow</u>	<u>q. q.</u>	<u>slow</u>	or
2	3	4 &	1	2	3	4 &	1	

Closed Position (CPos)* (Also called Waltz Position)

Partners directly face looking over each other's right shoulder; man holds lady's right hand in his left hand, with left arm extended to side about shoulder height; his right hand at her waistline (this varies with different dances and people); her left hand rests lightly on his right shoulder.

Open Position (OPos)* (Also called Conversational)

Man and lady are side by side facing same direction. Lady is on man's right with her left hand resting lightly on his right shoulder, his right hand is at her waistline. Other hand may or may not be joined.

Side Position (SPos)* RSPos - LSPos (Also called Parallel)

Man and Lady are side by side facing opposite directions. With right hips almost touching, position is Right Side Position. With left hips almost touching, position is Left Side Position. Lady's left hand rests lightly on man's shoulder, man's right hand is at lady's waist, other hands are joined as in Closed Position.

Hand to Hand

Man's Right or Left hand in lady's R or L hand. Partners facing or standing side by side.

Leading

The man must know what he is going to do and where he is going at all times. He usually leads off with his left foot.

He primarily uses his right hand (finger tips to the spine under the shoulder blade) to turn partner into and out of different dance positions. Man's left arm and hand gives additional directional lead. Man's right elbow should be held up contacting and supporting partner's left elbow. Man's left arm should be held comfortably up to the side - about shoulder height - almost straight.

Following

The lady must be sensitive to the man's lead and ready to reach back with the toes and take a long step backward. She must be aware of which foot her partner has free and which direction he is likely to move. She must at all times carry her own weight, centered over the ball of the foot. A certain degree of resistance to the man's lead, provides the man with something "solid" to guide across the dance floor. It is considered poor taste for the lady to lead. Keep in mind ballroom dancing is done with a partner for entertainment and enjoyment; it should interpret the music as to rhythm and quality; there is no absolute "right or wrong" - it is a matter of what works best.

LIST OF ABBREVIATIONS

L	Left (Side Direction) (Foot, Arm)	LFwd	Forward
R	Right " " " "	F	Front
LF	Left Foot	Bwd	Backward
RF	Right Foot	B	Back, Back of, or Behind
M	Man, man's, Men	Swd	Sideward
W	Woman, Woman's Women	Diag.	Diagonal
Ct	Count or Beat	LOD	Line of Direction, Line of Dance
Cts	Counts	OLOD	Opposite Line of Direction
Meas.	Measure (musical term indicating a grouping of beats)	CW	Clockwise
&	"and count (equal to $\frac{1}{2}$ beat or count)	CCW	Counter Clockwise
CPos	closed dance position	SPos	Side Dance Position
OPos	open dance position	X	Cross (as XRB = Cross Right Foot Back of Left)

TANGO

Like other ballroom dances, the tango is composed of a few fundamental figures which can be arranged to form innumerable combinations. The following are the most common figures unique to Tango.

Tango Break: (Forward, Side, Draw) (Gentlemen's part described)

<u>Count</u>	<u>Rhythm</u>	<u>Action</u>
1	quick	Step forward left
&	quick	Step sideward right
2	slow	Draw left slowly to right, weight remains on right
		Begin new pattern with left

Side Progressive:

<u>Count</u>	<u>Rhythm</u>	<u>Action</u>
1	quick	Step forward left
&	quick	Bring right close to left then a few inches to right side
2	slow	Bring left close to right and then step forward left - slightly diagonal to right
		Repeat new pattern with right foot

Habanera: (Rocking Step)

<u>Count</u>	<u>Rhythm</u>	<u>Action</u>
1	quick	Step forward (or backward or sideward) left Leave right foot in place
&	quick	Transfer weight onto right in place
2	slow	Transfer weight onto left any desired direction
		Repeat new pattern with right foot

The Habanera may be danced many different directions. The "transfer of weight" of the "rock" has a feeling of pushing into the floor, avoid bouncing.

Corté: (Dip)

The corté is usually a step backward onto man's left foot (lady lunges forward followed by a slight bend of the knee. However, the pattern may also be performed in many different directions.

Simple combinations of the above fundamental figures will be explored using a variety of dance positions and a variety of space (direction) patterns.

New Tango Combination I. Gentlemen's part described, lady follows on opposite foot.

77

Count	Rhythm	Action (CPos)*
1	slow	Step forward left (LOD) into a lunge, twist right shoulder forward
2	slow	Step backward right
3	quick	Step backward left (pull right shoulder back) Begin $\frac{1}{2}$ turn R
&	quick	Step side right
4	slow	Step forward left (OLOD). Turn. Complete.

Repeat stepping toward OLOD onto right foot; entire pattern reversed;
Total - 8 counts

1	slow	Step forward left, LOD
2	quick	Step sideward right; $\frac{1}{4}$ turn left
&	quick	Step backward left; XLB of R $\frac{1}{4}$ turn left
3	slow	Step backward right; LOD
4	slow	Step backward left; XLB of R; for full pivot turn to the right toward OLOD
5	quick	Step right; $\frac{1}{4}$ pivot turn right
&	quick	Step left; $\frac{1}{2}$ pivot turn right
6	slow	Step right; OLOD
7	quick	Step forward left
&	quick	Step sideward right
8	slow	Draw left to right

Total 8 counts } Tango Break
Report facing OLOD

New Tango Combination II

see Variations on a Theme in the Jaltz Section.

RUMBA

Cuban dance played in fast or slow tempo. The fourth beat is a hold. There is not a step on this beat, but actually the body should continue a slow roll into the beginning of the next beat. The movement is a subtle continuous quick and slow rolling motion of the weight from foot to foot. Hip action is a result of a smooth rolling motion of the knees and the weight shift into the feet, while the upper body is quiet. The steps should be short and flat footed, with the knee leading. The upper body is held high and straight and does not reflect the action of the feet, knees, or hips. The free arm is held to the side with the elbow bent; palms are facing. The open and encircling patterns reflect a subtle flirtatious quality.

Basic Rumba: (Box)

Count	Rhythm	Action
1	quick	Step left to left side
2	quick	Close right to left
3-4	slow	Step forward left

* See Abbreviations

<u>Count</u>	<u>Rhythm</u>	<u>Action</u>
1	quick	Step right to right side
2	quick	Close left to right
3-4	slow	Step right backward (or forward)

Rumba Breaks: (A suggested sequence)

Break 1: Lady is on Gentlemen's left; her right hand in his left. Allow elbows to be bent for "leading tension." Man moves backward - lady forward.

Break 2: Man turns and places his right hand in lady's right hand. Both move forward in a circle.

Break 3: Still holding right hands, lady travels around behind man while man dances in place and finishes on man's left side. Man holds lady's left hand in his left hand - like Varsouvianne Position but lady is on man's left side. Man now moves backward - lady forward.

Break 4: Still holding left hands, but releasing right hands, man now pulls lady across in front of him with a turn, lady is now on man's right Varsouvianne Position. Man now moves forward, lady backward.

Change to break number 2 position; change hands and return to closed dance position.

Rumba Spot Turns:

same as in Samba and Waltz

SAMBA

The SAMBA is the most active of the South American dances and comes from Brazil. The meter is 2/4, rather fast, suggesting a happy, bouncy quality. The easy springing bounce on the two accented beats together with a rocking motion create a pendular action.

Basic Step:

<u>Count</u>	<u>Rhythm</u>	<u>Action</u>
1	quick	Step forward left (upper body leans backward)
&	quick	Step right close to left
2	slow	Step left in place
1	quick	Step backward right (upper body leans forward)
&	quick	Step left close to right
2	slow	Step right in place

Copa Step: (open dance position) (travels forward)

<u>Count</u>	<u>Rhythm</u>	<u>Action</u>
1	quick	Step forward left
&	quick	Step in place right
2	slow	Step left forward (or backward) (like a <u>chug</u>)
		Right same starting right

Samba Box - and Turning:

like a Waltz; forward, side, close

Spot Turns:

same as in Rumba and Waltz

WALTZ

<u>Count</u>	<u>Rhythm</u>	<u>Action</u>
1	- slow	- Step forward L
2	- slow	- Step sideward R.
3	- slow	- Close L to R
1	- slow	- Step backward R
2	- slow	- Sideward L
3	- slow	- L to R

Use the above basic waltz for "turning left" or "counter clockwise."
Reverse the above by starting backward on left, then forward on right for a "right turn" or "clockwise turn."

Basic Jazz Waltz

<u>Count</u>	<u>Rhythm</u>	<u>Action</u>
1 - 2	slow	Step forward L
and	quick	Step side R
3	slow	Close L to R

Note the rhythm is uneven. Another form of analysis would be

<u>1</u>	and	<u>2</u>	and	<u>3</u>	and
Slow			Quick Slow		

Another Jazz Waltz step - (Mazurka)

<u>Count</u>	<u>Rhythm</u>	<u>Action</u>
1 - 2	slow	Step L
and	quick	Hop L
3	slow	Step R
Repeat, starting LEFT		

Waltz Spot Turns (also used in Samba-Rumba)

<u>Count</u>	<u>Rhythm</u>	<u>Action</u>
1	slow	Step - L to L
2	slow	Step R X back of L
3	slow	Step L in Place (Half Turn Right)
1	slow	Step R in Place
2	slow	Step L in Place
3	slow	Step R in Place

Spot Turns will be developed for Rumba - Waltz - Jazz Waltz - Samba.

VARIATIONS ON A THEME

An Experiment

Now start at the bottom of the page and read up -- like reading a road map.

		8 Meas. 3/4	8 Meas. 4/4	
Close (or X)	R	3	S 7-8	
Side	L	1/2 Turn L	Q 6	
Back	R		1	Q 5
Hold		3	4	
Draw	R to L	2	3	
Back	L	1	S 1-2	
Close	R	3	S 7-8	
Side	L	1/2 Turn R	Q 6	
Forward	R		1	Q 5
Hold		3	4	
Hold		2	3	
Dip B	L	1	S 1-2	
		4 Meas. 3/4	4 Meas. 4/4	
Touch	L to R	3		
Draw	L to R	2	S 7-8	
Side	R	1	Q 6	
Close	L	3	Q 5	
Side	R	2	S 3-4	
Forward	L	1	S 1-2	
In Place	R	1/2 Turn L	Q 8	
In Place	L		2	Q 7
XRF of L		1	S 5-8	
In Place	L	3	Q 4	
Side	R	2	Q 3	
<u>Forward</u>	L	1	S 1-2	
(Man's Part)		Waltz	Tango	

UP
READ ↑

1964 SANTA BARBARA FOLK DANCE CONFERENCE

Presented by C. Stewart Smith

LAGACH ANNA - Bonnie Anne (Scotland)
 or
 AN RIOGHAL LEANABH - The Royal Child

- SOURCE:** The story, steps and music were given to Mrs. MacNab by an elderly lady who came from Argyllshire to settle in Prince Edward Island, Canada. The story goes that a band of gypsies stole a little girl from her home in England. She was brought to Scotland and reared with gypsy children. She always seemed to be different and kept much to herself, so the Highland folk called her "An Rìoghal Leanabh." As she grew to womanhood and was considered the best dancer in the village, one of the dances was named for her: Lagach Anna - Bonnie Anne.
- MUSIC:** Record: Parlophone PMD 1029 - 10", Side 1, Band 1, Jimmy Shands Band.
- FORMATION:** A four cpl dance. First lady is always "Bonnie Anne".

Fig. I.

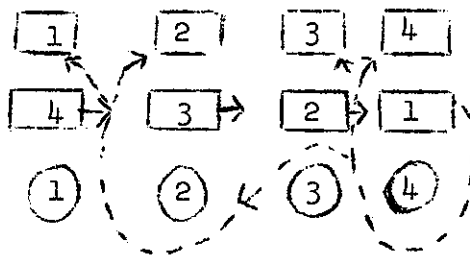

Measures
1-16

Fig. II.

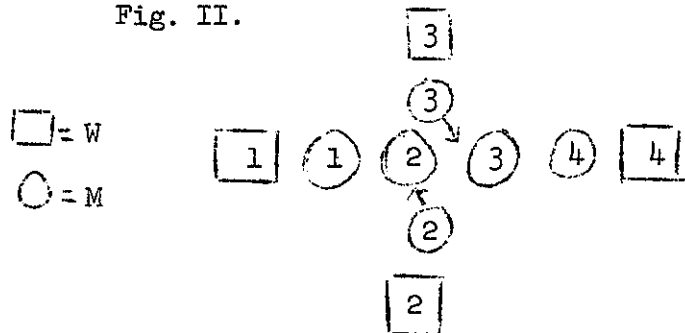
Pattern

All cpls dance the first 16 bars of the Petronella.
Petronella Turning for "Bonnie Anne"

Measures

1-2	Pas de Basque, turning to R
3-4	Set to ptr (up and down)
5-6	Repeat counts 1-2 (turning)
7-8	Repeat counts 3-4 (across the dance)
9-10	Repeat counts 1-2 (turning)
11-12	Repeat counts 3-4 (Up and down)
13-14	Repeat counts 1-2 (turning)
15-16	Repeat counts 3-4 (across the dance)

17-32

First cpl set to each other - lady moving over to face ptr. They turn with two steps, finishing first lady facing second man - first M in his own place. First lady now sets to and turns second, then third and then fourth M. Each setting and turning takes four bars and is done with

Measures

pas de basque.

As first lady turns her ptr second lady dances up into first woman's place, then crosses to first M and turns him while first W is setting to and turning second M. Third and fourth ladies do the same, and on Bars 29-32 first lady is setting to and turning fourth M while second lady is doing the same with third M - third lady with second M and fourth lady with first M.

NOTE: As second lady steps up so do 3rd and 4th. i. c. the ladies keep all moving up, the moving up is done with skip change of step.

- 1-8 Rpt. First lady goes round behind fourth M, in front of third M, behind second M, then crosses over to her own place at the top of the set - eight skip changes of step. At the same time second lady dances down in front of fourth M and following first lady finishes in her original place, while third and fourth ladies follow, but they, after dancing round fourth M, return to original places (Fig. I.)
- 9-16 All set twice and turn ptr with R H. On the last step turn ptrs under R arm to finish in Varsouvienne Position. All face top of set.
- 17-20 First cpl with 4 pas de basque steps move slightly forward, then round by the right, to finish side by side facing down the dance.
- 21-24 Second cpl dance out to the L and round to stand side by side on the M's side of the dance. Four pas de basque steps. Beginning with L ft.
- 25-28 Third cpl turning to R finish side by side on the W's side of the dance. Four pas de basque steps.
- 29-32 Fourth cpl turn R round by the R to finish facing 1st cpl. The dance is now in the form of a square.

II. MEN'S SOLO

- 1-4 All four M dance into the ctr, taking 2 pas de basque to enter and 2 to turn to face ptr.
- 5-8 All set with pas de basque or high cuts. On the last bar finish in pos, for reel of four. (Second M moves in to face first M and third M moves in to face fourth M, second and third M are back to back in the middle (Fig. II.)
- 9-16 Reel of four up and down the dance for 6 steps. On seventh and eighth steps, the M turn and dance to stand in front of ptrs.

Reel of Four As For "Bonnie Anne"

When the reel is danced in a line of four as in "Bonnie Anne", the figure is begun by the men who are facing one another passing by the right shoulder, then passing the man met in the middle by the left shoulder, while those going to the outside move round by the right to face the middle of the dance. If you remember to keep the left shoulder for the middle of the reel and follow the curve of the 8 at the end of the figure, the formation is quite simple.

Measures

- 9 Pass by R shoulder
- 10 Curve round by R shoulder
- 11 Dance into center
- 12 Pass by L shoulder in center
- 13 Pass by R shoulder
- 14 Curve round by R
- 15-16 Dance out to face ptr.

NOTE: This figure is danced with much vigor as the men have felt that the ladies had the most of the dancing in the previous figures. Throughout this figure the ladies dance quietly in place. They must not take away the interest from the M's solo, i. e., they dance eight balance and pas de basque.

17-24
25-32

All set twice to ptrs and turn with two Hs.
All poussette back to 2 straight lines, retain ptrs R hand; all bow and curtsy.

Poussette for "Bonnie Anne"

In this poussette there is no progression, the first and second couple dance round one another, while third and fourth couple do likewise, from a square position and end in the original line position. The movement takes 8 bars of music and is done in a diamond formation; couples one and two dancing along one diamond formation, while couples three and four do likewise along another diamond formation, as follows:

Measures

- 1 Travel
- 2 Turn
- 3 Travel
- 4 Turn
- 5 Travel
- 6 Turn
- 7 Travel
- 8 Turn into a line

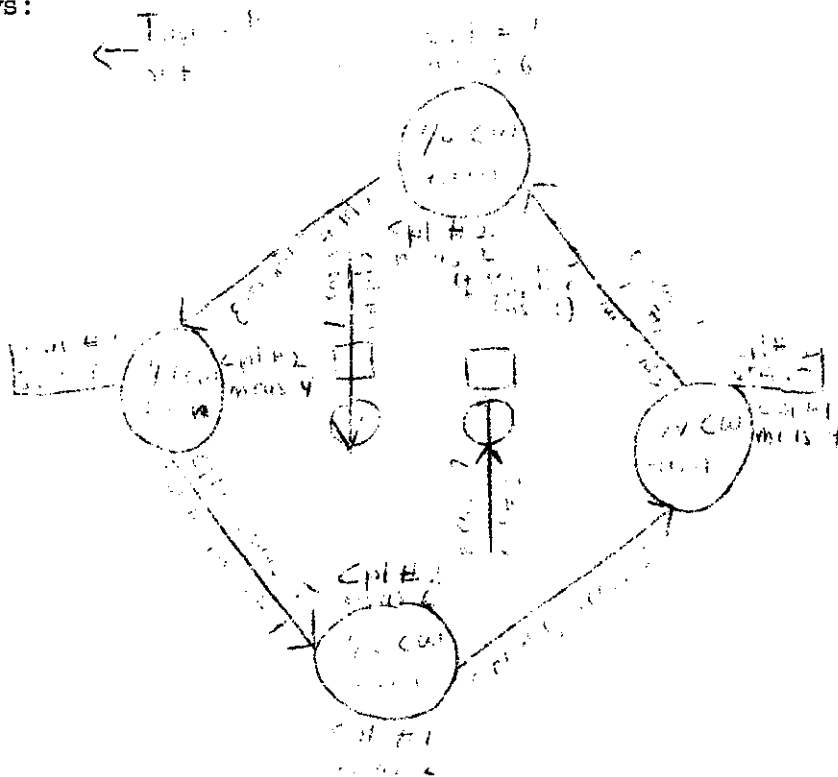

POUSETTE
for
"BONNIE ANNE"

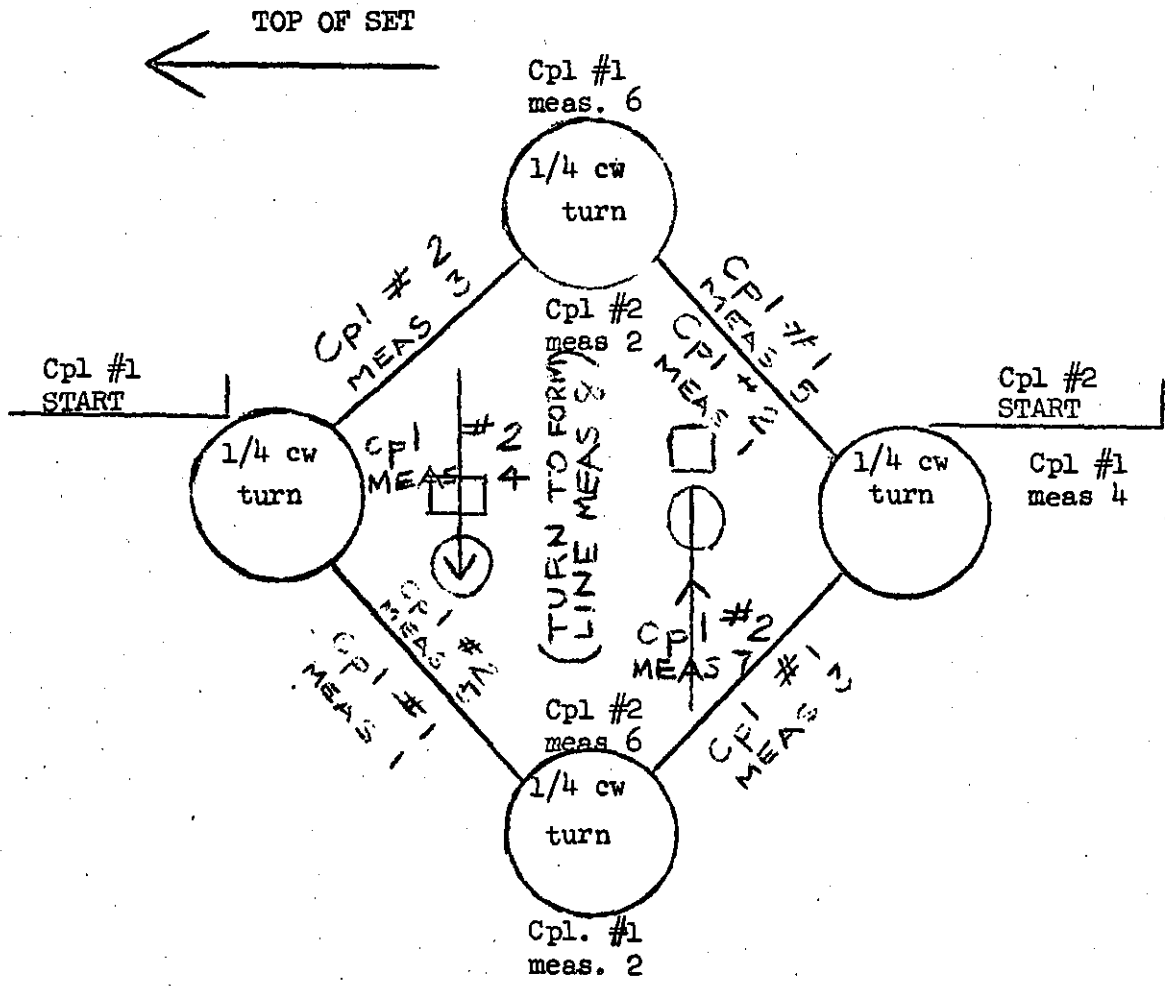

1964 SANTA BARBARA FOLK DANCE CONFERENCE

Presented by C. Stewart Smith

CUMBERLAND REEL (Jig)
(Scotland)

RECORD: Capitol "My Scotland" LP T10014

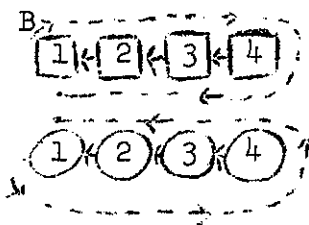
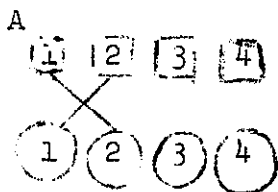

MUSIC.	DESCRIPTION
Bars.	
1-4	First and second couples give right hands to one another and dance round. "Four hands across." (Fig. A.)
5-8	Turn, and giving left hands, dance back to places.
9-12	First couple lead down the middle.
13-16	and up again.
17-28	First woman casts off, turning to the right behind the women, while the first man casts off, turning to the left behind the men, the other men and women following (Fig. B) for six steps, then lead up the middle to places for six steps. On 6th step first couple turn to face down. All other couples join hands with partners to make arch.
29-32	First couple dance down the middle under their arms. On last bar all drop hands and step back. The first couple remain at the bottom of the dance, and the second couple repeat the figure.

Tune: "Cumberland Reel."

1964 SANTA BARBARA FOLK DANCE CONFERENCE

Presented by C. Stewart Smith

THE GLASGOW HIGHLANDERS (Strathspey)
(Scotland)

RECORD: Capitol "My Scotland" LP T 10014

Fig. A.

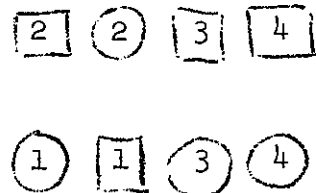
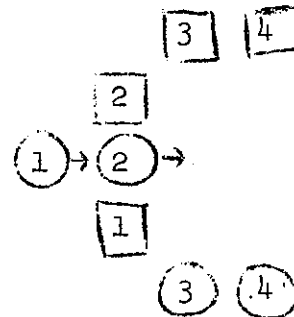

Fig. B.



On the second chord first woman crosses over to right hand side of partner. Second man takes his partner's place while she moves up to top. (See Fig. A).

MUSIC. BARS.	DESCRIPTION
1-4	First and second couples "right and left" -- that is, they pass their vis-a-vis giving right hand and then partners giving left.
5-8	Right and left again, back to places.
9-12	As second man gives his left hand to his partner he dances into the middle offering his right hand to first woman who has been handed over to him by her partner. All three lead down the middle, the first man following. Let go hands and all turn. The man turning the woman towards him while both men turn right about.
13-16	First man gives left hand to his partner and right hand to the second woman, and they all three go up the middle, the second man following. First and second couples face partners -- the women outside, the men inside, back to back (as in Foursome Reel).
17-24	First and second couples set to partners with simple Strathspey steps.
25-32	Reel of four across the dance. On the last steps, first man giving his partner right hand leads her down side to face next couple, while second couple change to own sides at the top where they stand. Repeat, having passed a couple.

THE GLASGOW HIGHLANDERS (CONT'D) Page -2-

Suggested Strathspey step: Forward on right, hop; back on left, hop; step behind with right, step left, right and hop.

NOTE: During the 7th and 8th bars of the reel of four, the third man crosses over and places himself on the left of his partner who takes a step to the right; the first couple finish on the men's side one place down. Each man having in turn crossed to the side of his partner, stays on the women's side till he reaches the top. He and his partner then stand still on their own sides for one turn, at the end of which the woman crosses over to her partner's right hand side, and they dance all the way down on the men's side. At the bottom each couple stand on own side for one turn before the man crosses over to his partner to work up to the top again.

Tune: "The Glasgow Highlanders," or any Strathspey with 32 bars.

1964 SANTA BARBARA FOLK DANCE CONFERENCE

Presented by C. Stewart Smith

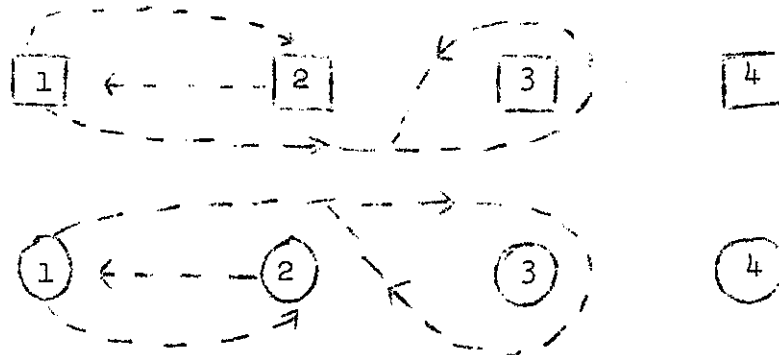
THE MACHINE WITHOUT HORSES (Jig)
(Scotland)

MUSIC. BARS.	DESCRIPTION
1-4	First couple set and cast off one place. Second couple move up.
5-8	First and third couples right hands across, dancing once right round.
9-12	First couple set and cast up one place. Second couple move down.
13-16	First and second couples left hands across, dancing once right round.
17-24	First couple, followed by the second couple, lead down between third couple and cast up round them. Lead up to the top, and then cast off into second place while second couple dance up to the top. (Fig.)
25-32	First and second couples right and left. Repeat, having passed a couple.

Tune: "The Machine without Horses".

Rutherford 1772

1964 SANTA BARBARA FOLK DANCE CONFERENCE

Presented by C. Stewart Smith

WALTZ COUNTRY DANCE (Scotland)

RECORD: Mercury "Step We Gaily" LP Mei 203

FORMATION: Stand in fours round the room, as in Figure:

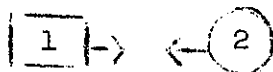
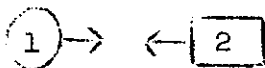

MUSIC. BARS.	DESCRIPTION
1-2	Each man and woman balance to the man or woman opposite,
3-4	and crosses to change places, passing, right shoulder, women making a waltz turn by the right and men moving straight forward.
5-8	Balance to partners and again change places.
9-12	Repeat bars 1 to 4.
13-16	Balance to partners and change places.
17-18	All four taking hands, balance forward and backward.
19-20	Men continuing to balance on spot turn the woman on their left to the place on their right (with both hands).
21-24	The same again (bars 17-20).
25-28	The same again.
29-32	The same again.
33-40	Waltz pos. passing couple with whom they have just danced to meet the next couple.

NOTE: Steps used in 3/4 time Pas de Basque, omitting fourth beat.
Change of step omitting skip.

Tunes: "Come o'er the Stream, Charlie" (Waltz), "Speed, Bonny Boat."

From "The Ballroom," 1827.

1964 SANTA BARBARA FOLK DANCE CONFERENCE

Present by C. Stewart Smith

THE BIRKS OF INVERMAY*

TUNE: Original or any good slow strathspey

TIME: 4/4

This is a longways strathspey dance for 3 couples. A new top couple begins on every third repetition.

Bars

- 1-4 1st man and 2nd lady joining both hands turn round and return to places. 4 travelling steps.
 - 5-8 1st lady and 2nd man do the same.
 - 9-16 1st, 2nd and 3rd couples, joining both hands crossed in front, promenade. 8 travelling steps.
 - 17-24 1st couple joining right hands in passing, cross over and cast off one place, lead up between 2nd couple, and, crossing over to own side, cast off into 2nd place. 8 travelling steps.
 - 25-32 1st, 2nd and 3rd couples make a circle and dance 4 travelling steps round to the left and 4 back again.
- 1st couple repeat dance with next 2 couples.

* "101 Scottish Country Dances" compiled by Jean C. Milligan published by Collins: Glasgow & London 1956.

1964 SANTA BARBARA FOLK DANCE CONFERENCE

Presented by Elizabeth Ullrich
and Morrie Gelman

DER PFEIFER (Austrian)

- SOURCE: Danced in Vienna, Austria, in 1931, by a group from Saxony, at a Youth Festival.
- MUSIC: Record: Bowery 219-A. In 1931 the music was arranged especially for this dance. It is taken from "The Pfeifer Rheinlander" by Joseph Strauhs.
- FORMATION: 4 cpls make a set. All facing CCW in a double circle, W to R of M. M's free hand on hip; W's free hand hold skirt. Inside hands joined with ptr.
- STEPS: Walk; run; schottische; step-hop.

Music 2/4

PATTERN

Measure

4 meas.

Introduction

Walk fwd in LOD 4 steps, swinging joined hands bwd and fwd; then M turns W CW under joined hands. End facing ptr, M back twd ctr. Begin on outside ft.

I. CLAPS

- 1-2 Clap own knees, own hands, ptrs hands; then put hands on hips and look twd own R shoulder.
- 3-4 Repeat action Fig. I, meas. 1-2, look to L.
- 5-8 R elbow hook, hooked hands held high waving a handkerchief or hat, walk around with ptr CW 8 steps, finish facing ptr.
- 1-8 rptd. Repeat action Fig. I, meas 1-8, finishing facing LOD, inside hands joined.

II. ARCHES

- 1-2 Cpl #1 (in front) make arch. Cpl #2 run 8 small steps fwd thru arch.
- 3 W make R turn in place.)
- 4 M make L turn in place.) inside hands still joined
- 5-8 #2 cpl make arch; 1st cpl run thru, W turn; M turn. Finish in a circle of 2 cpls, hands joined. M #1 moves bwd on M's turn so circle is arranged MW MW.

III. CIRCLING

- 1-4 Beginning L ft, circle CCW with 2 schottische steps and 4 walks.
- 5-6 Again beginning L, circle CW with 2 schottische steps.
- 7-8 With 4 walking steps, form a double circle, all facing in twd ctr, W on inside, M's hands on W's shoulders, W's hands on hips.

DER PFELFER (CONT'D) Page -2-

IV. TEASING

- 1 Move to L with a step-close step, W looking at M over R shoulder, M looking into W's eyes.
- 2 Move to R, repeating action meas 1-2, Fig. IV.
- 3-4 W turn CW, M clap hands.
- 5-8 Repeat action Fig. V, meas 1-4.
- 9-10 W step-close twice to L and twice to R, M hands still on W's shoulders, and doing same step action.
- 11-12 Both, beginning L run fwd twd ctr 4 steps, then W turn quickly 1/2 to L, trying to shake M off, but not succeeding; run out away from ctr 4 steps.
- 13-24 Facing out, repeat the step-close sequence, run out from ctr, turn and turn in twd ctr again, W joining hands in a circle at end of meas 24.
- 25-32 L on 16 th ct. Beginning on R, circle CCW 12 running steps. Then M pull W straight out from ctr (W drop hand hold reluctantly) with 4 more steps.

2 meas interlude. Face ptr, R hands joined, M facing LOD, W back to LOD.

V.

- 1-4 Move in LOD with 2 schottische steps, W turning CW under joined hands during 4 step hops of meas 3-4.
- 5-8 Repeat action Fig. V, meas 1-4.
- 9-12 Moving diagonally fwd, separate from ptr with one schottische step; return to ptr with one schottische step; take shoulder-waist pos and turn CW once with 4 step-hops.
- 13-16 Repeat action Fig. V, meas 9-12.
- 17-18 Inside hands joined, both facing LOD, dance 1 step-close step to L and 1 step-close step to R.
- 19-20 Cpl turn CCW 1/2 way round, M dancing in place, W moving around, with 4 step-hops.
- 21-24 Repeat action Fig. V, meas 17-29, ending with W on outside facing in, M inside facing out.

FINALE

- 1-2 Move bwd away from each other with 4 running steps. M begin L ft; W, R ft.
- 3-4 Run fwd twd ptr 4 steps, again clapping. Then join R hand with ptr. Clapping hands once.
- 5-8 Turn once around CW with ptr with 8 fast running steps.
- 9-16 Repeat action Finale, ending with W on outside, M on inside of circle. Bow to ptr, R hands joined.

1964 SANTA BARBARA FOLK DANCE CONFERENCE

Presented by Elizabeth Ullrich
and Morry Gelman

DR EIGETALER (Switzerland)
Also known under the name "Churer Mazurka"

MUSIC: From "d Landlermusic" von AL Gassmann, op 42
RECORD: Schallplatten
FORMATION: Couples in large circle - facing CCW, social dance position
STEPS: Mazurka, three-step, step-close step

Fig. 1A

Meas. 1-2 Two Mazurka steps, starting M L, W R
3 1 three-step turning away from each other, keep inside hands joined, M hands on hips, W hold skirt
4 1 three-step back and take dancing position.
5-8 Repeat meas. 1-4, ending in Varsuvianne position.

Fig. 1B

Meas. 1-2 Two Mazurka steps fwd toward center
3-4 1/2 turn CW in place with 2 three-steps
5-6 2 Mazurka steps fwd away from center
7-8 1/2 turn CW in place with 2 three-steps

Fig. 2A

Meas. 9 Couples side by side hands on hips
One three-step with 1/2 a turn M l CCW, W r CW away from partner
10 2 stomps, M R, W L, (don't care look)
11 1 three-step back, M starting R, W L
12 2 stomps (smile at each other)
13 Partner take upper arm hold and with 1 Mazurka step 1/2 turn, both starting L
14 2 stomps, L R in place, W inside of circle M outside of circle
15-16 Repeat meas. 13-14, on last meas. in original position
9-16 Repeat Fig. 2

Fig. 3

Meas. 1 Couples facing CCW dancing position
2 1 Mazurka step forward M L, W R
2 steps backward, M L, W R exchange places, W turns under M R and her L arm (always keep hand hold) both turn
M CCW, W CW now facing CW
3-4 Repeat Meas. 1 and 2, CW
5-8 Repeat Meas. 1-4
9-12 Repeat Meas. 1-4 of Fig. 1
13-14 2 Mazurka steps forward

DR EIGETALER (CONT'D) Page -2-

- 15-16 Drop hand hold, with 2 three-steps, one complete turn
M CCW, W CW, M hands on hips, W hold skirt.
17-32 Repeat Meas. 1-16

Fig. 4

- Meas. 1 Couples turning in place with one step close step L
sideways and one cross step R in back of L
2 Step close step starting L and cross R in front
3-8 Repeat meas. 1 and 2 turning 3 1/2 times on last meas.
M should be on the outside
9-16 As meas. 1-8 starting R ft. ending with M inside

Repeat Fig. 1A

- Meas. 1-8
1-8

Repeat Fig 1A
" " 1B

Fig. 1B

- Meas. 9-12 Repeat Fig 2 meas. 9-12
13-14 2 Mazurka steps forward
15-16 Couples complete turn with 2 three-steps CW

1964 SANTA BARBARA FOLK DANCE CONFERENCE

Presented by Elizabeth Ullrich
and Morrie Gelman

ERZGEBIRGISEHER VOLKSTANZ (German)
dar Vuglborhoom (der Vogelbaibaum)
From Dr. Alfred Memil

MUSIC: Dar Vuglorboom RECORD: Schallplatten
STEPS: Cross balance, waltz, three steps, pivoting
FORMATION: Couples in a circle, facing each other, M back to center,
W back to outside.

MEAS.

1 Step L ft circle with a light stomp (ct 1); step R across
L (ct 2); step back in place on L (ct 3).
2 Starting with R ft
3-4 Turning 1 complete turn, step L R L, look back to partner
5-6 To Right
7-8 To Left
9-16 Repeat meas. 1-8 starting with Right, turning R on last
meas. under arm hold and
17-18 One waltz step L, one waltz step R, in place
19-20 Repeat meas. 17-18
21-24 Four waltz steps turning CW moving CCW
25-28 Repeat meas. 17-20 starting R
29-32 Four waltz steps turning CCW moving CW

FIG. II

In circle, M behind W

1-4 M starting L, four three-steps forward following W clapping
hands, W 2 three-steps forward, on the third and fourth
three-step, make a turn R turning CW.
5-16 Repeat meas. 1-4 three more times. On the last measure,
take dancing position.
17-20 Four waltz turns R turning CW moving CCW
21-22 Drop hand hold and do 2 three-steps away from each other.
23-24 Two three-steps toward each other.

MEAS.FIG. II (continued)

25-32

Repeat meas. 17-24.

FIG. III

Couples side by side in circle facing CCW, hands in back, R in R, L in L.

1

All couples one three-step L, forward toward circle.

2

One three-step R out of circle.

3-4

Couple makes a complete turn in place with 2 three-steps, M backward, W forward, CCW.

5-6

Make a turn with 2 three-steps, W backward, M forward CW.

7-8

As meas. 3 and 4.

9-16

Repeat meas. 1-8.

17-18

Join inside hands, face LOD and step close balance or hop with outside ft, M L, W R.

19-20

As meas. 17-18 starting inside ft.

21-24

Join both hands arms open, four waltz steps in place.

25-32

Repeat 17-24. After the last meas. form a large circle, facing in.

FIG. IV

1-8

M dance 8 waltz steps in place, starting L then R, alternating. W meas. 1 and 2, two three-steps toward center, join R hands form a star, M meas. 3-4 two three-steps forward CW, on count four turn to a L hand star, meas. 5-6 with two three-steps back to position, making a 1/2 R hand turn.

9-16

Repeat meas. 1-8 but M to center and star R and L as M come back link R arm with R arm of W.

17-20

Turning with four three-steps CW.

21-24

But link L arms turn CCW.

25-32

Repeat 17-24.

Repeat FIG. IV.

1964 SANTA BARBARA FOLK DANCE CONFERENCE

Presented by Elizabeth Ullrich
and Morrie Gelman

STAMPF POLKA
(Switzerland)

SOURCE: Old Bündner Tänze from Graubünden Canton, Switzerland
by Martins Bodrutt.

MUSIC: Record: Schallplatten

STEPS: Two Step--Hop--Polka

FORMATION: Couples facing each other in single circle.

Meas. 1 Two-step close step to center of circle

2 One step close and stomp twice, M R, W L

3-4 Two polka steps starting M R, W L with a 1/4 turn
clockwise and back to position.

(Glocken Polka)

5-6 As meas. 1-2 out of circle

7-8 Four step hops with two turns CW in place. On last
count, drop hold, hands on hips - couples facing each
other.

9 All one polka step L, away from each other, M toward
center W out of center.

10 One polka step R back to circle, and change in place;
partners are standing now back to back with partner.

11-12 Join R hands with new partner and do 4 step hops CW
once around, back to position M, facing CCW, W CW.

13-16 Repeat meas. 9-12 4 times in all. Repeat whole dance.
It should end with the first meas. 1-8.

1964 SANTA BARBARA FOLK DANCE CONFERENCE

Presented by Dani Dassa

DEBKA HABIR
(Israeli)

RECORD: TIKVA T-69 "Dance Along with Sabras"

FORMATION: Line, face circle center, arms bent close to body, join hands.

PART I:

- 1-5 Bounce on heels
- 6 Hop on R
- 7 Touch L heel forward bending R leg
- 8 Close with L and straighten legs
- 9-32 Repeat 1-8 3x.

Formation: Facing R in line, hands behind back, L hand gripping R wrist, R hand closed, head facing L.

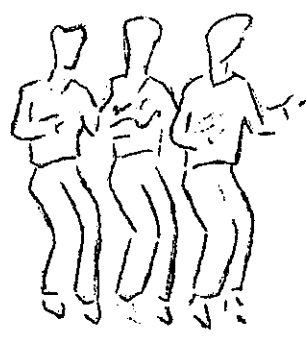

Part II:

- 1 Step on R fwd in LOD
- 2 Kick L leg out to L side
- 3 Bring L back behind R
- 4 Bring R leg to R side
- 5-8 Repeat 1-4 starting with L
- 9-16 Repeat 1-8
- 16-32 Repeat 1-16

Formation: Facing R in LOD, R hand forward, L back, joining hands.

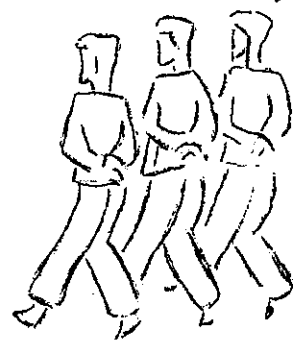

Part III:

- 1-2 Step on R fwd LOD
- 3-4 " " L " "
- 5 Step R fwd bending knee, L off floor to the back
- 6 Shift weight to L in back lifting R off floor fwd, knees bent.

DEBKA HABIR (CONT'D) PAGE -2-

- 7 Brush sharply bkwd with R, and jump off floor
- 8 Land on R - L bent in back and off floor
- 9 Stamp L behind R rising heels off floor - head facing L
- 10 Hold
- 11-12 Bounce in place on heels
- 13 Hop on R moving to L (sideways)
- 14 Leap onto L moving to L (sideways)
- 15 Close with R
- 16 Hold
- 17-32 Repeat 1-16

Formation: Facing center, arms holding at shoulder level

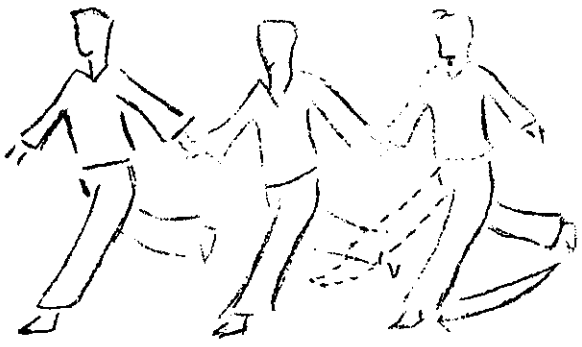

Part IV:

- 1-2 Stamp R to R side (taking wide step)
- 3-4 2 stamps L using ball of foot, cross behind R
- 5-12 Repeat 2x
- 13-14 Quick Yemenite step R
- 15 Leap in place onto L - at same time kick R fwd
- 16 Close with R
- 17-32 Repeat 1-16

Formation: Arms are joined downward, head stays always in direction of progression.

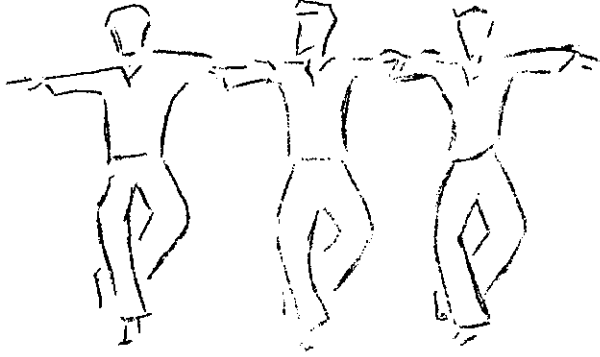

Part V:

- 1-2 Stamp R to R (taking wide step), hold (release hands)
- 3-4 Stamp L to L making 1/2 turn to R - hold
- 5 R crosses behind L
- 6 L to L side
- 7 Hop on L
- 8 Stamp R crossed behind L using ball of foot
- 9-16 Reverse 1-8, starting with L
- 17-32 Repeat 1-16

DEBKA HABIR (CONT'D) PAGE -3-

Formation: Line face CCW - hands joined down

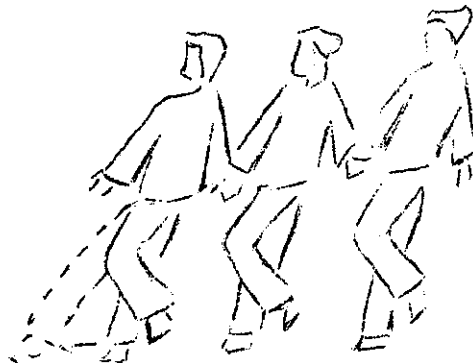

Part VI:

1-2	Stamp R & hold
3-4	Brush L fwd - leap on L fwd
5-6	Stamp R (with ball of foot) back and hold
7-8	Close with L and hold
9-10	Stamp R and hold
11-12	Brush L and hop on R
13-14	L fwd - R bkwd
15-16	Close L to R and hold
17-24	Like 1-12